

newline

User Manual

DV Element LED Display



* Please read the manual thoroughly and save it before attempting to connect, operate or adjust the product.

before attempting to connect, operate or adjust the product.

newline

CONTENTS

	Catalogue	1		
	Safety Guides	3		
	Important Warnings	4		
	Copyright	5		
	Warnings	5		
	Qualified Professional	5		
	Safety Regulations	6		
	Document Description	6		
	Agreement	6		
	Description	6		
01	1. Product Overview	7		
	1.1 Product Features	7		
	1.2 Packing List	7		
	1.3 LED Cabinet	9		
02	2. Installation Guide	10		
	2.1 Precautions	10		
	2.2 Installation Dimensions	11		
	2.3 Installation Steps	12		
	2.3.1 Seat installation	12		
	2.3.2 Front installation	15		
03	3. Maintenance	18		
	3.1 Attentions	18		
	3.2 Display maintenance	18		
	3.3 Cleaning	23		
	3.4 Common Fault Analysis	24		
04	4. LED Cabinet packaging removal	25		
	4.1 Box packing method	25		
	4.2 Cabinet packaging removal method	25		
	Transportation and delivery	26		
	Transportation	26		
	Storage	26		
	Unpacking	26		
	Warranty	27		

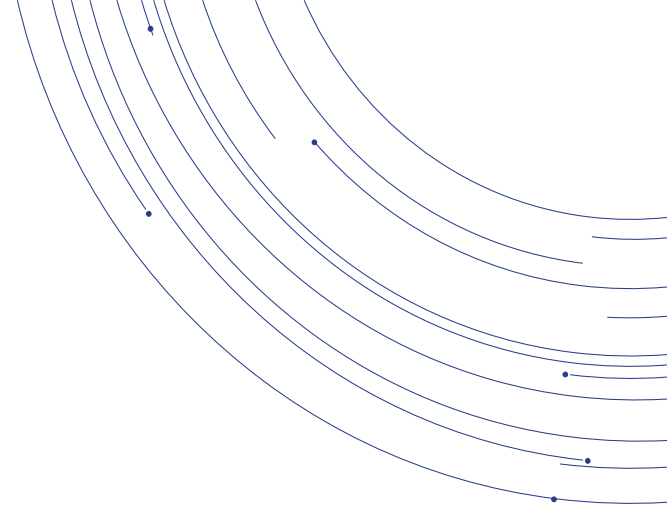

Safety Guides

- ◆ Please read the manual carefully and follow its instructions before using the product.
 - ◆ Please complete the installation according to the installation method provided in the user manual.
 - ◆ Do not place the front of the product on an irregular surface to avoid permanent damage to the display surface of the product..
 - ◆ Do not place the product on a tilted or unstable table or cardboard, as this may cause the product to fall or tip over, which may result in permanent damage to the product.
 - ◆ Do not place heavy objects on the power cable to avoid damaging the cable and causing electric shock or fire.
 - ◆ Do not repeatedly bend and move the power or data cables for a long time to avoid damage and cause electric shock or fire.
 - ◆ Please connect the power and data cables according to newline recommendations.
 - ◆ Please tie and fix the power and data cables in a neat row after completing the cable installation, and separate the strong and weak power.
 - ◆ Please clean the screen regularly, using a nano sponge to clean the screen. If you have any questions about cleaning products, please contact customer service.
 - ◆ Please use the screen in a well-ventilated environment.
 - ◆ Do not expose the product to prolonged contact or exposure in an environment with a large amount of dust, strong acidic or alkaline substances, otherwise it may cause permanent damage to the product.
 - ◆ Do not place equipment that emits high heat or sources of ignition around the screen.
 - ◆ Please use original accessories from newline, if you need to use self-purchased accessories, please consult our customer service staff.
- Arrange regular professional inspection of the screen.

Important Warnings

WARNING: DANGER OF ELECTRIC SHOCK

- High Voltage hazard. Non-professionals are prohibited from opening the LED cabinet. It is prohibited to plug or unplug the power plug with power.

WARNING: DANGER OF PERSONAL CASUALTIES

- High altitude workers must take corresponding protective measures to avoid accidents.

WARNING: KEEP AWAY FROM FLAMMABLES AND EXPLOSIVES

- Keep the screen away from inflammables and explosives.

CAUTION: POWER ON REGULARLY

- When not in use for a long time, regularly turn on the screen power to extend the product's service life.

CAUTION: CLASS I EQUIPMENT AND GROUNDING IS REQUIRED

- The screen needs to be grounded.

CAUTION: POWER SUPPLY

- When connecting the product to be power supply, please pay attention to load balance and strictly prohibit overloading. Please ensure that the working voltage of the screen is suitable for the local power grid voltage before installation.

Copyright

•newline reserves the right to make change this manual. In the event of any subsequent changes to the product, no further notice will be given. We are not responsible for any direct, indirect, intentional or unintentional damages or hidden dangers caused by improper installation or use of the product manual.

Warnings

Precautions:

For your personal safety and to avoid unnecessary property damage, it is important to pay attention to the prompts in this manual. The reminder for personal safety is indicated by ⚡. The reminder only related to property damage does not include a warning triangle. The warning reminder varies from high to low according to the level of danger, as follows:

⚠ DANGER: indicates that failure to take appropriate protective measures may result in death or serious personal injury.

⚠ CAUTION: indicates that failure to take appropriate protective measures may result in minor personal injury.

Note: indicates that if corresponding protective measures are not taken, it may lead to unexpected results.

Qualified Professional

The products outlined in this manual are exclusively intended for operation by professionals who fulfill specific job requirements. Their operations must adhere strictly to the accompanying documentation instructions, particularly the safety and warning prompts. Through relevant training and experience, professionals possess a comprehensive understanding of this product, enabling them to mitigate potential hazards during operation.

Safety Regulations

- Non professionals are not allowed to disassemble the product without authorization to avoid high-voltage electric shock.
- If you are unsure of the local power grid voltage, please consult with the local power supply operator.
- High altitude workers need to have corresponding safety protection measures.
- The frame structure of LED display should be designed and constructed by professionals.
- Make sure to take safety measures for grounding the equipment.

Document Description

Scope of this document

This document is applicable to DV Element series outdoor fixed LED display screen of Newline company.

Agreement

In this document, the term "screen" or "product" specifically refers to DV Element series products, outdoor fixed installed LED display screens.

Description

To avoid property damage and for personal safety reasons, please pay attention to the safety information in this manual. The text uses a warning triangle to indicate these safety messages, and the appearance of the warning triangle depends on the degree of potential danger.

1. Product Overview

- Pixel pitch options of P6.67/P8/P10, suitable for outdoor fixed installation with IP65 waterproof and dustproof rating.
- The aluminum profile cabinet process improves the flexibility of product production, and different specifications of cabinets can be produced according to the order requirements.
- The cabinet can be accessed through rear or front for maintenance.

1.1 Product Features

- Aluminum sheet metal box , 26.5kg / m² .
- Convenient maintenance, control box and module can be maintained from both front and back, making it convenient and efficient.
- Excellent image quality with professional color processing technology, high contrast and refresh rates for perfect detail reproduction.
- Comprehensive advertising solutions with hardware, software, and content.
- Energy-saving and environmentally friendly with precise automatic brightness adjustment and ultra-low voltage energy-saving circuit design.
- Note: The above product parameters are for reference only. The specific contract parameters shall prevail.

1.2 Packing List

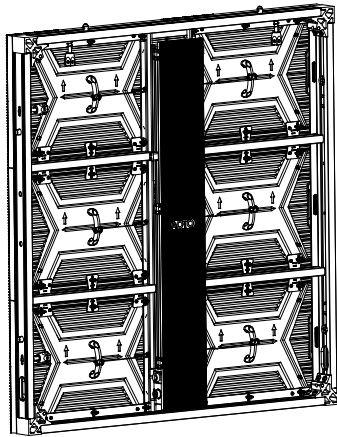
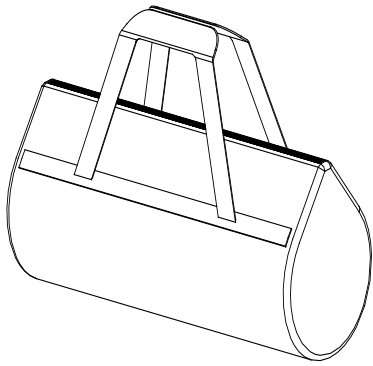
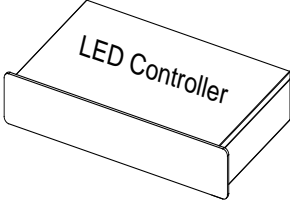
		
<p>LED Cabinet</p>	<p>Tool cabinet</p>	<p>LED Controller</p>

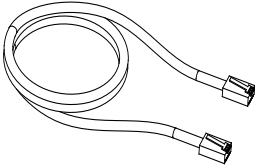
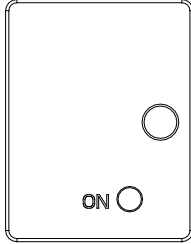
	
<p>Cat 5E data cable (optional)</p>	<p>Power Distribution Box (optional)</p>

Note: the above accessories are for reference only, and the details are subject to the requirements of the order.

1.3 LED Cabinet

This product is shown in the figure below (some features have been simplified).

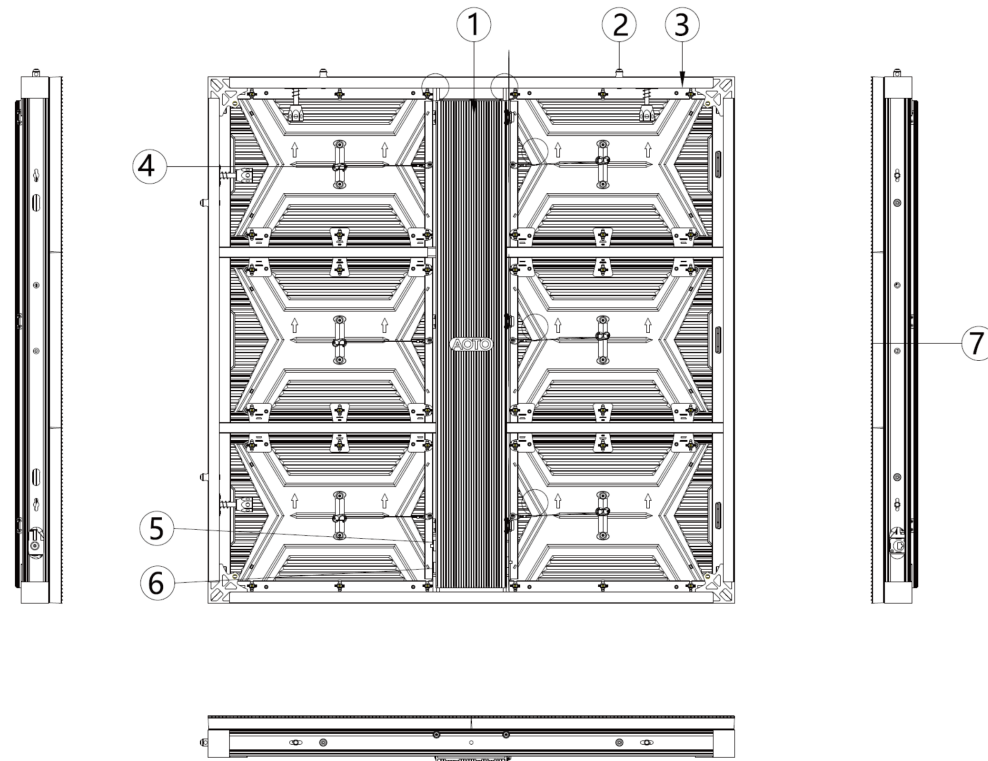

NO.	Description	Mark
1	Control box door cover	To open the swing door cover, simply unlatch the latch on the right side of the door cover. Inside the door cover, there are power supplies, primary and secondary HUBs, indicator buttons, and a scanning card.
2	Cabinet locating pin	Positioning device between the upper, lower, left and right of the cabinet.
3	Frame	The supporting structure which houses the control box, installation modules, safety ropes, power supplies, control cards, and other equipment.
4	Safety rope	A rope used to prevent the module from falling during maintenance.
5	Signal Connector	A component that serves as the input/output interface for the LED cabinet.
6	Power Connector	A component that receives the AC power supply for the LED cabinet.
7	Module	Display application, Each LED cabinet contains 6 modules.

2. Installation Guide

Before installing this product, please carefully read the following safety instructions and formulate strict safety assurance measures to ensure construction safety.

2.1 Precautions

1. After unpacking the product, please check for any damage or scratches.
2. The installation structure of the LED display screen should be designed and constructed by professional personnel.
3. At least two people should participate in the installation process as a safety precaution..
4. Necessary precautions should be taken to prevent the product from falling during installation.
5. When working at heights, the operator should properly utilize safety belts and safety helmets.
6. Ensure that the bracket and support beam of the LED display screen are level.
7. The bracket and support beam of the LED display screen should possess adequate strength. Following installation, they should not undergo any deformation.
8. Avoid dropping objects on the LED display screen.
9. Do not install this product in an enclosed environment, as it may impact heat dissipation and display performance. In cases where specific site environment requirements exist, ensure there are designated ventilation channels both in front of and behind the unit.
10. It is strictly prohibited to install the product in an environment where iron shavings, wood chips, or paint fumes are generated.
11. When moving the LED cabinet, avoid direct contact with the LED diodes and implement anti-static measures to prevent static electricity from causing damage to the LED diodes or IC devices.
12. If the LED cabinet needs to be temporarily positioned before screen installation, ensure it is placed with the light face up. If placing the light face downwards is necessary, please use anti-static cushioning material underneath. When positioning the box body vertically with the light face outward, avoid exerting pressure on the light beads.

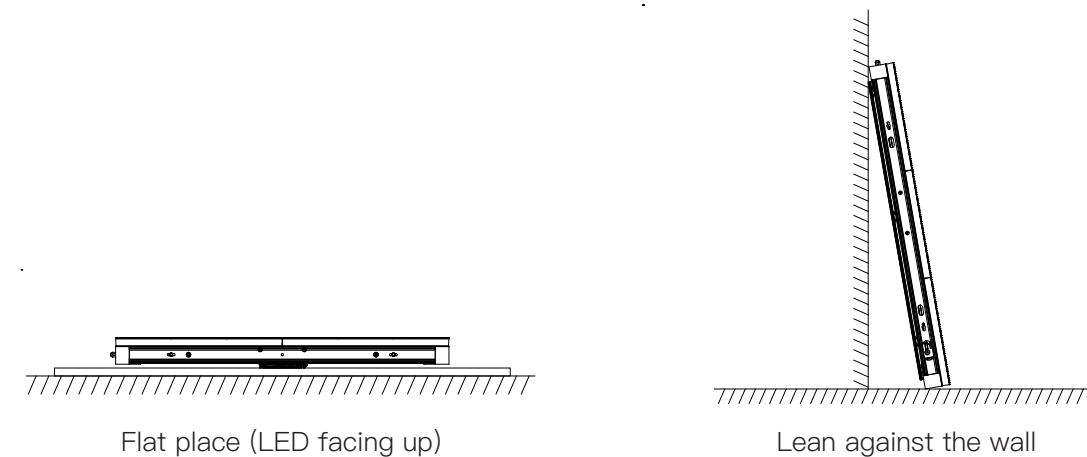

13. Please be careful to avoid the LED panel being bumped or pressed when placing the box temporarily.

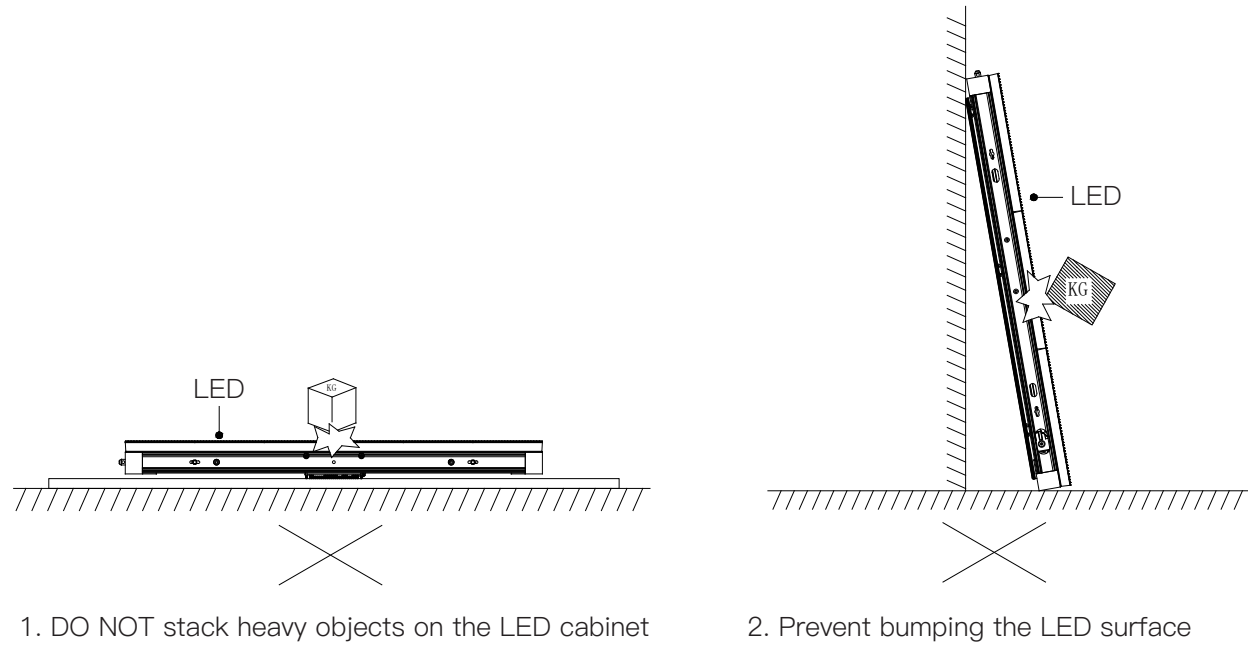

2.2 Installation Dimensions

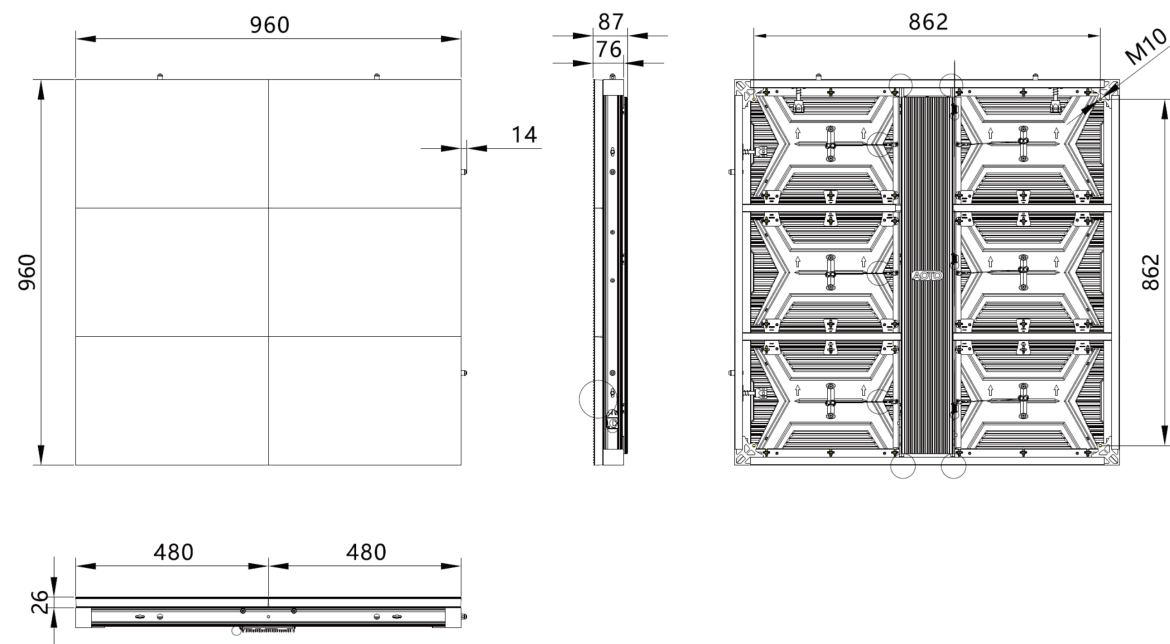

2.3 Installation Steps

2.3.1 Rear Installation

The following parts and tools are needed for fixing the box during installation:



Electric batch

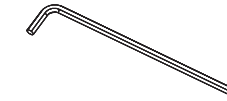

Inner six angle(8mm)

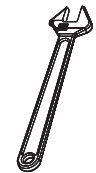

Adjustable wrench

Step 1: Installing the first cabinet

Smoothly place the first cabinet on the horizontal beam base, and then utilize an 8mm hex wrench to securely fasten the cabinet to the mounting frame using the connecting plate and M10 screw. (Please note that the installation frame structure depicted in the figure is for reference purposes only and should be adjusted according to the actual engineering application scheme.)

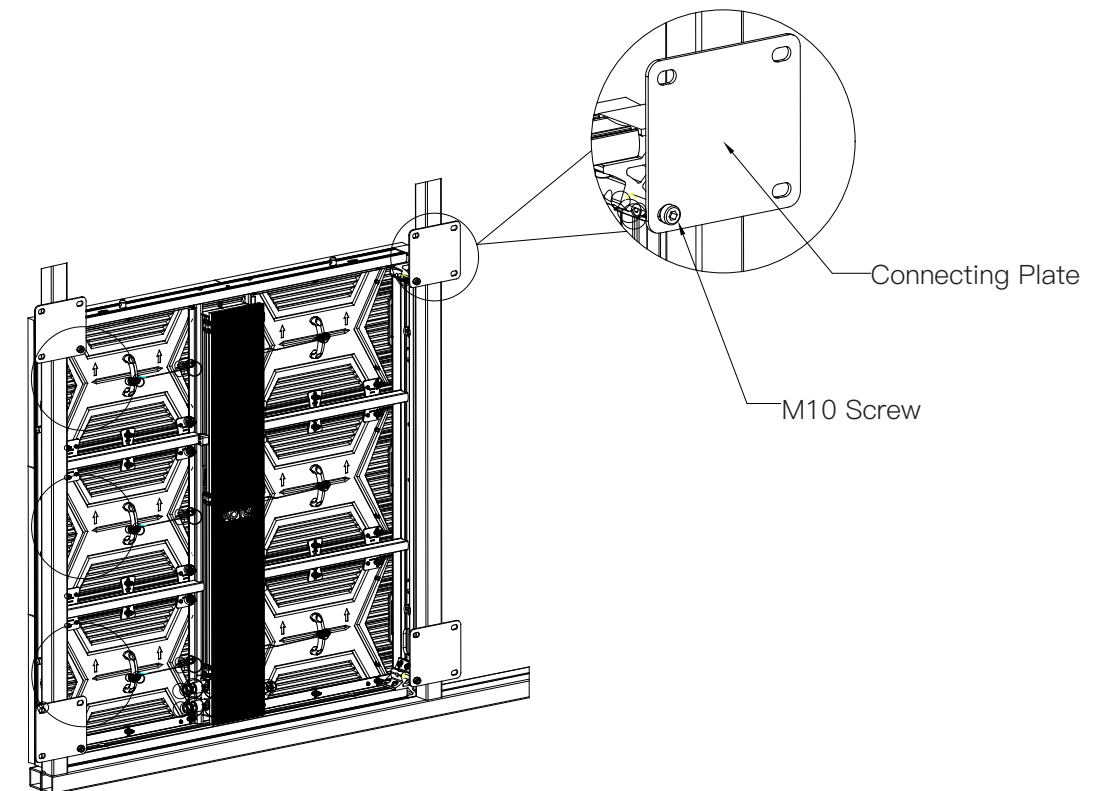

Step 2: Installation of the second cabinet in the first row

Place the second cabinet onto the horizontal beam, and then secure the adjacent cabinets using the connecting plate and M10 bolt (do not fully tighten, allowing for some movement but ensuring the cabinet remains stable). Insert an M8 bolt through the right frame of the cabinet and into the left frame of the adjacent cabinet. Tighten them together using M8 nuts and washers while adjusting the levelness of the two cabinets. Subsequently, firmly lock the connecting plate and M10 bolt.

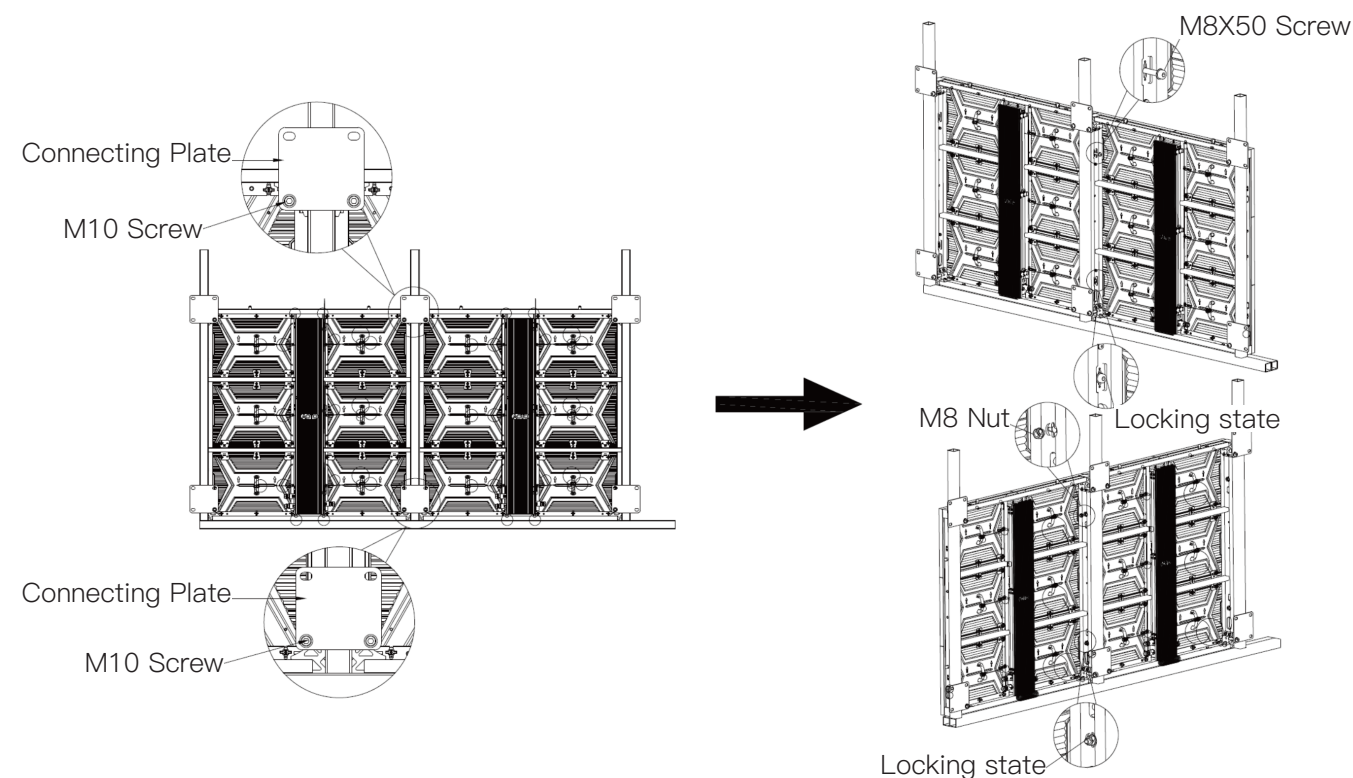

Step 3: Install the first cabinet of the second row

Stack the top cabinet onto the bottom cabinet and use connecting plates to secure the cabinet to the steel structure to prevent any risk of falling. Then, employ the methods outlined in steps one and two to firmly fix the cabinet in position.

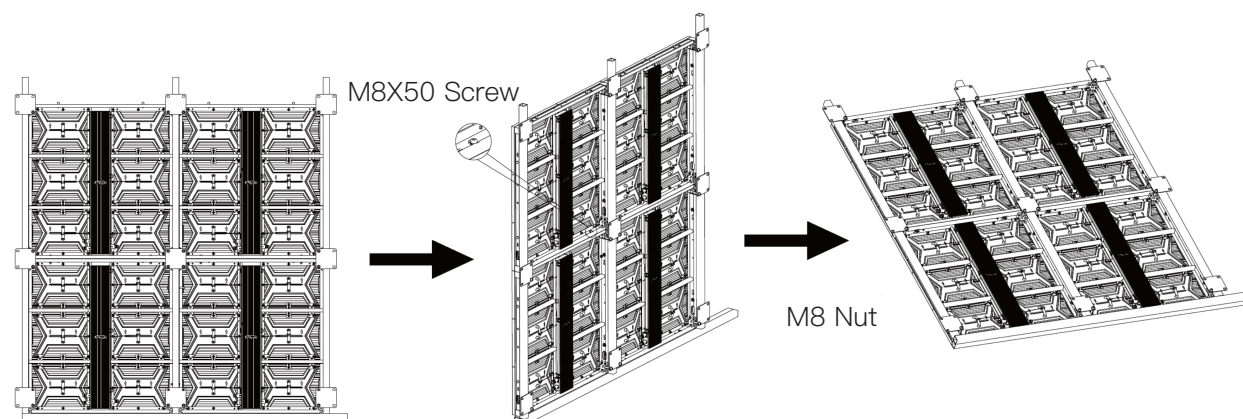

Step 4: Install the remaining cabinets at the rear, adhering to the installation procedure of the initial row of cabinets. Route the external power cable and network cable into the back of the screen. Select a suitable wiring method based on the specific application requirements of the project.

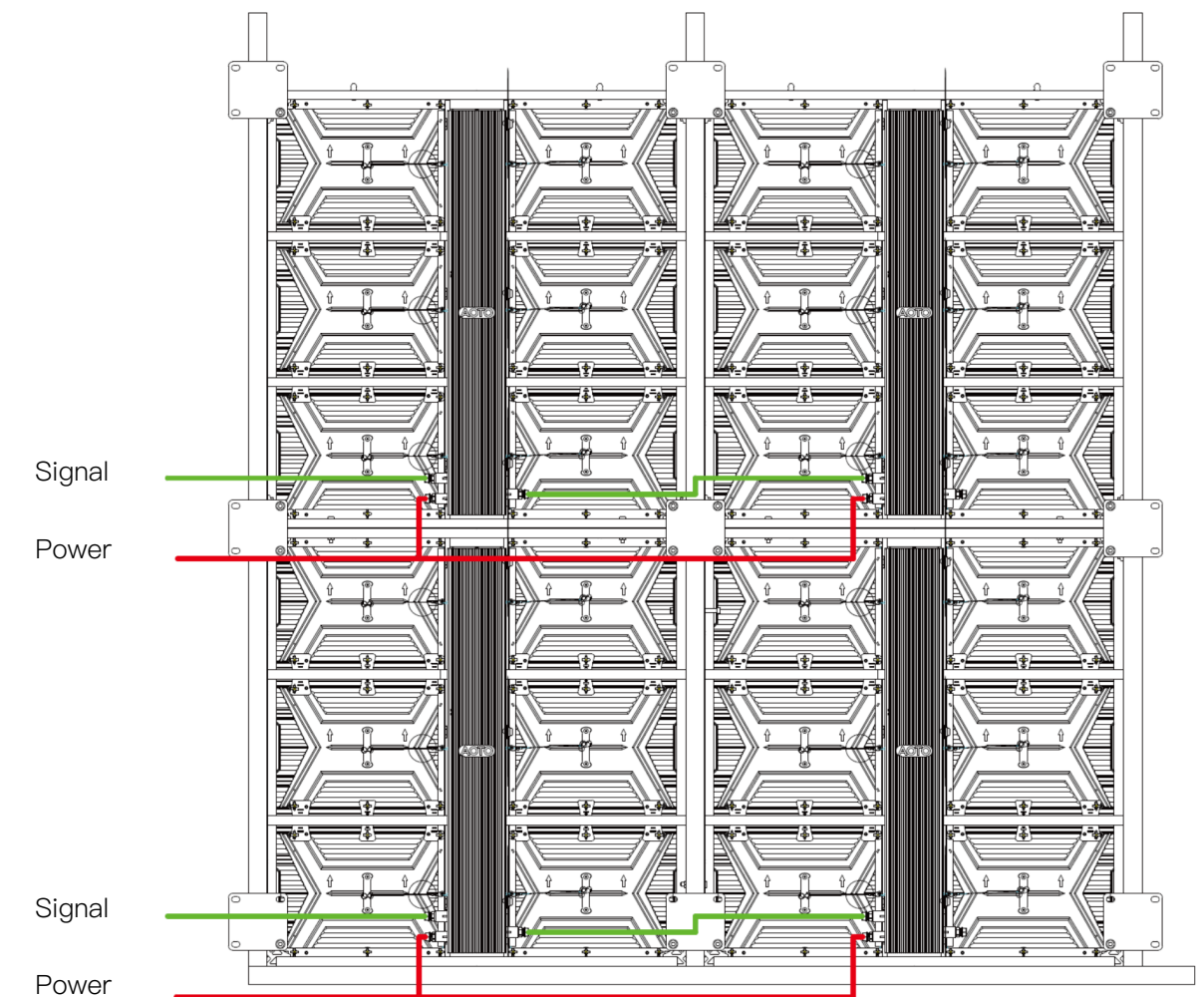

External wiring mode

Attention:

1. When connecting cabinets, avoid attaching power or network cables to prevent the risk of electric shock.
2. Ensure to securely tighten the screws of the power cable to prevent product damage from excessive current during power-on, which could potentially lead to a fire hazard.
3. Do not overload the power cable with an excessive load.
4. Follow the power cable connection plan provided as depicted in the system diagram.
5. Adhere to the network cable connection plan as outlined in the system diagram. Alternatively, utilize other connection methods if the network cable length allows.
6. Upon properly inserting the network cable into the signal input port, expect to hear a distinct 'click' sound as an indicator of correct insertion.

2.3.2 Front installation

The parts and tools required for the fixed installation of the cabinet are as follows:



Electric batch



Inner six angle(8mm)



Adjustable wrench

Step 1: Installing the first cabinet

Using a 2.5mm hex wrench, carefully remove the modules from the four corners of the first cabinet. Subsequently, smoothly place the cabinet onto the horizontal beam base. Utilize a 6mm hex wrench along with connection plates and M8 screws to firmly secure the cabinet to the installation frame. (Please note that the installation frame structure depicted in the figure is for reference purposes only; the actual engineering application scheme should be followed.)

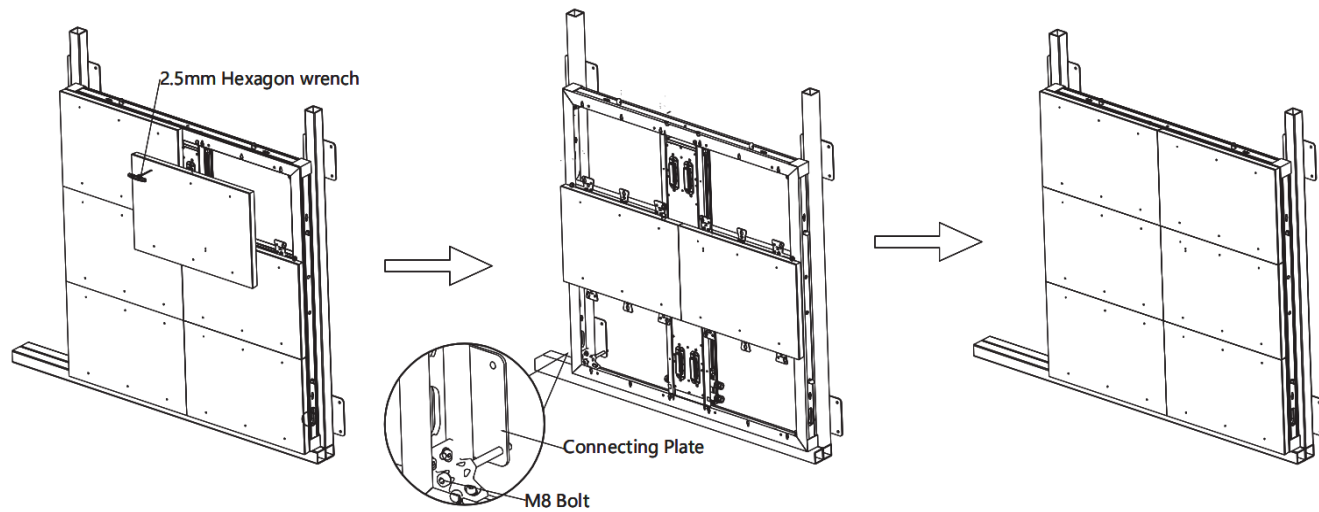

Step 2: Install the second cabinet of the first row
Place the second cabinet onto the horizontal beam and temporarily secure the adjacent two cabinets using connecting plates and M8 bolts without fully tightening them, allowing for slight movement to ensure cabinet stability. Insert M8 bolts through the right cabinet frame into the left cabinet frame and secure them with M8 nuts and washers. Adjust the flatness of the two cabinets as necessary, then proceed to lock the connecting plates and M8 bolts securely.

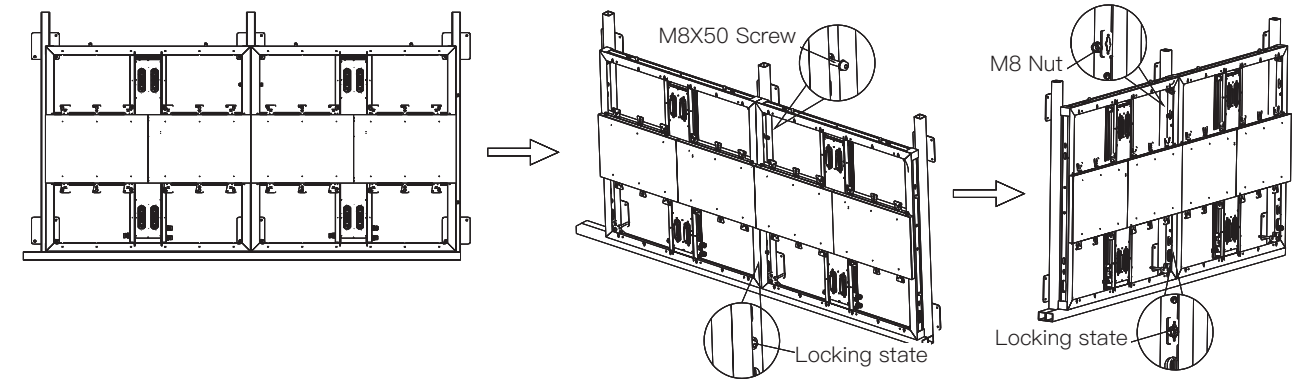

Step 3: Install the first cabinet of the second row

Stack the top cabinet onto the bottom cabinet and secure them together using a connecting plate to affix the cabinet onto the steel structure, ensuring it is stable and prevents any risk of falling. Proceed to use M8 screws to securely tighten and level the two boxes. Adjust as necessary to ensure proper alignment and stability.

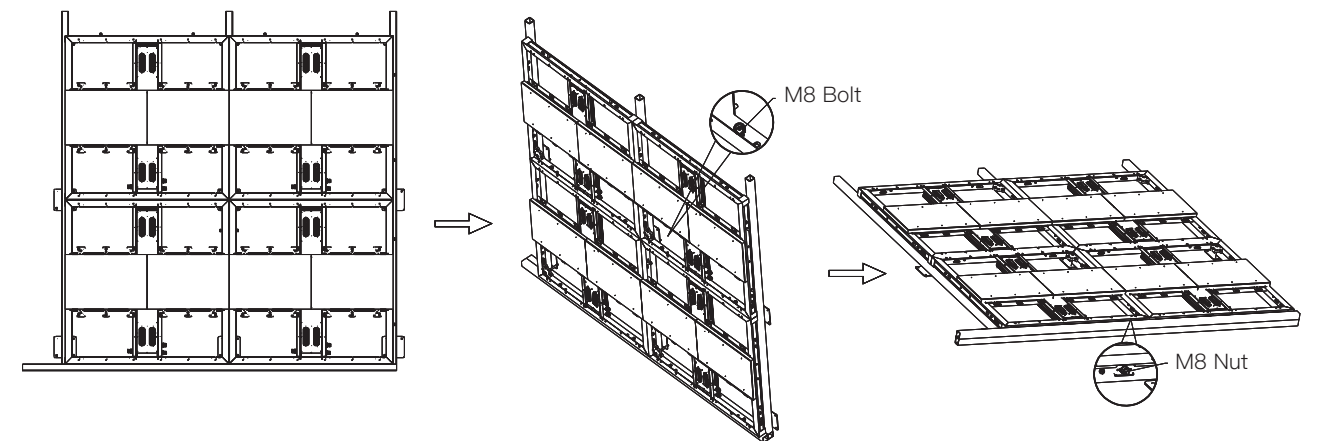

Step 4: Following the installation method employed for the first row of cabinets, proceed to install the remaining cabinets accordingly. External power and data cables can be routed into the screen from the rear. Select the appropriate connection method based on the specific requirements of the engineering application.

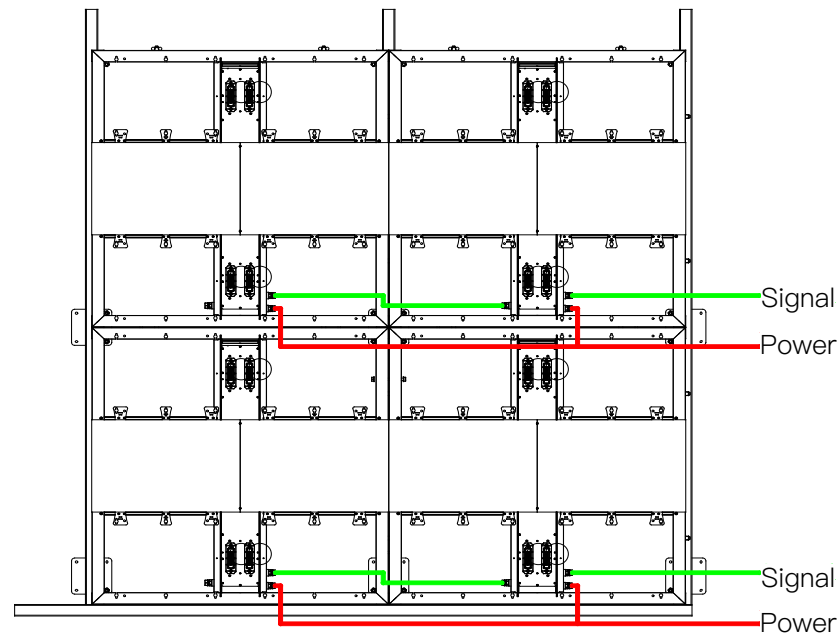

External wiring mode

- Attention:
1. Avoid powering on the cabinet while connecting the power cable and data cable to mitigate the risk of electric shock.
 2. Ensure to securely tighten the screws of the power cable to prevent product damage from excessive current during power-on, which could potentially lead to fires.
 3. Do not overload the power cable with excessive load.
 4. Follow the power cable connection scheme provided by AOTO as depicted in the system diagram.
 5. Adhere to the data cable connection scheme provided by AOTO as outlined in the system diagram. Alternatively, if the data cable length allows, consider alternative connection methods.
 6. Upon properly inserting the data cable into the signal input port, expect to hear a distinct "click" sound as an indicator of correct insertion.

3. Maintenance

3.1 Attention

1. Before conducting maintenance on the LED display screen, ensure to cut off the power supply to prevent the risk of electric shock and injury to individuals.
2. While performing maintenance, be mindful to protect the surface of the module to prevent any damage.
3. During maintenance tasks, take precautionary anti-static measures and wear anti-static gloves to prevent static electricity from causing damage to the lamp beads.
4. Exercise caution when removing modules vertically to prevent collisions with adjacent module edges, which could lead to damage or detachment of LED light beads.

3.2 Screen maintenance

This product facilitates post-module install maintenance, and the tools necessary for such maintenance include a 2.5mm hex wrench, a cross screwdriver, and a front maintenance tool, as illustrated in the figure below:

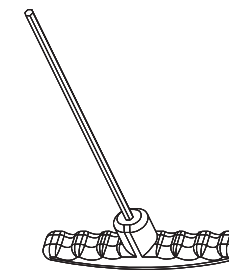

Hexagon wrench

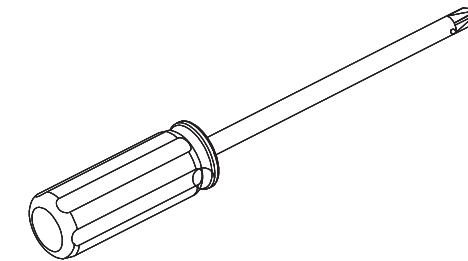

Cross screwdriver

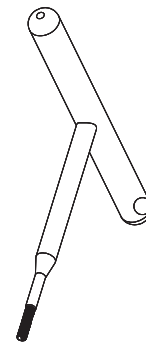

Front maintenance tools

The main steps for rear maintenance of the cabinet are as follows:

Step 1: Turn off the power of the screen and unplug the power and signal cables.

Step 2: Loosen the buckle on the back cover of the control box to open it. Inside, you will find the power supply and HUB. Utilize a cross screwdriver to disassemble and perform maintenance on them.

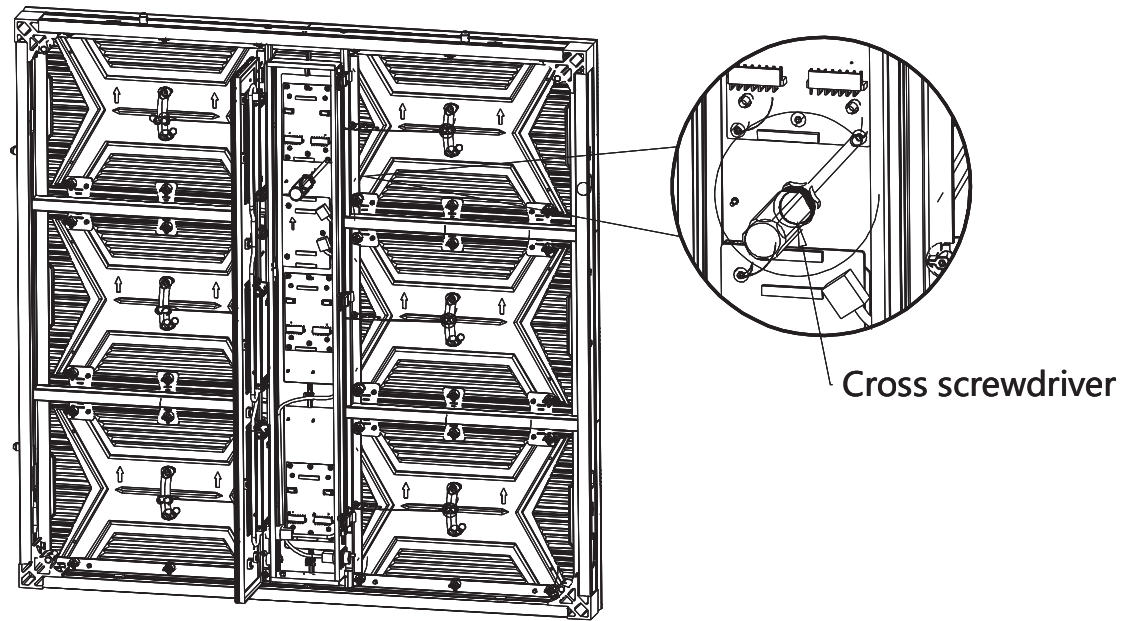

Step 3: As shown in the figure below, use a 2.5mm hex wrench and front maintenance tool to remove the module for maintenance;

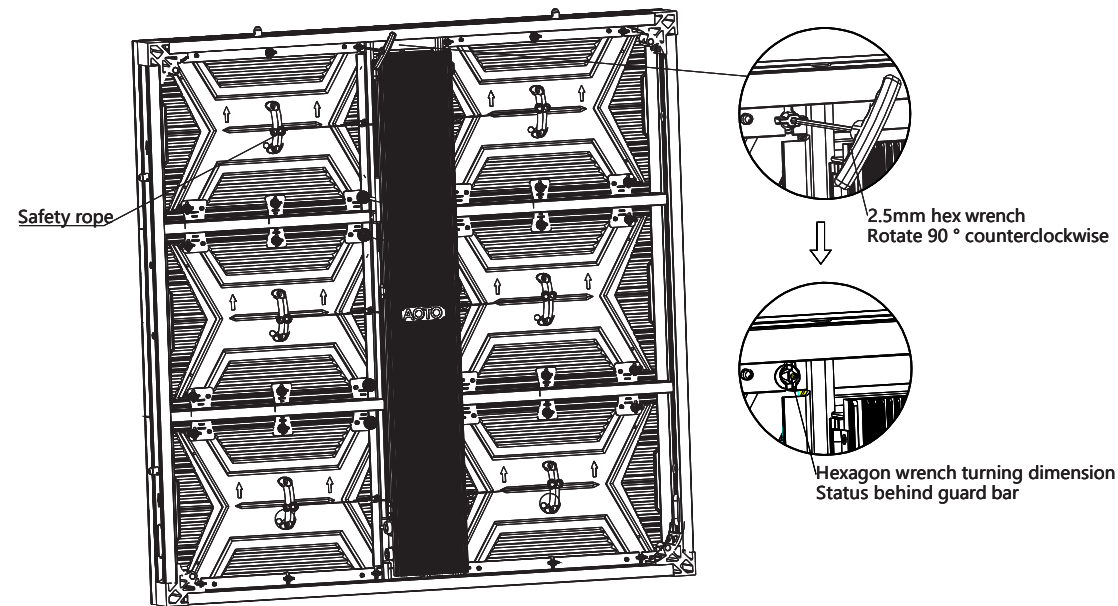

Step 4: After loosening the six maintenance rods on the module, grasp the module handle with one hand and push the module forward with the other hand to remove the module from the box body, as shown in the figure.

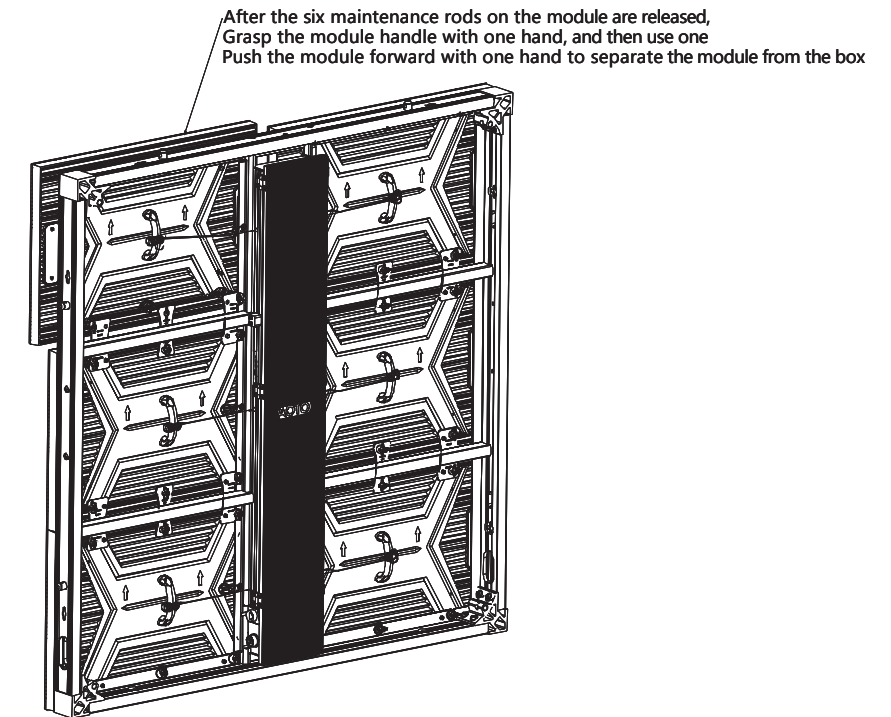

Step 5: Once the module is brought to the back of the cabinet, remove the safety rope buckle attached to the module, and proceed to repair the light board as depicted in the figure.

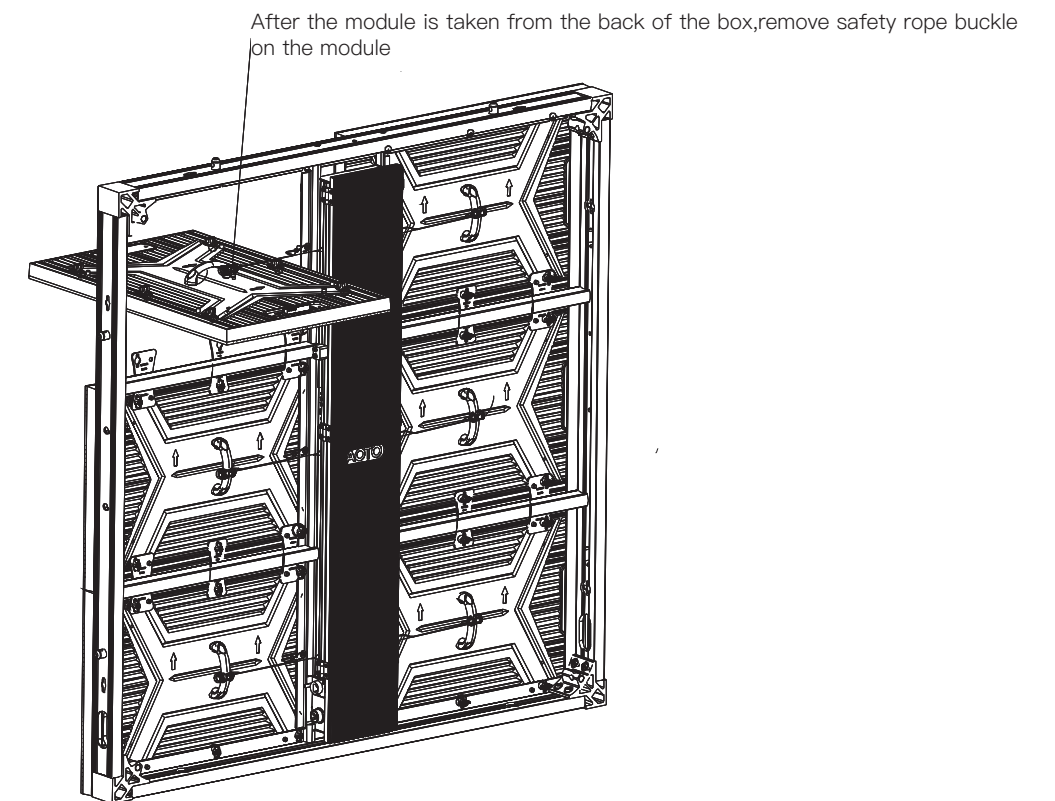

Step 6: Following module repair or replacement, secure the safety rope lock buckle onto the module handle. Position the maintenance rods at the previously removed angle. Install the module onto the frame and align it with the module data port position. Utilize the front maintenance tool to firmly pull the module back, ensuring complete attachment to the cabinet. Finally, use a 2.5mm hex wrench to rotate the maintenance rod and lock the module in place, as illustrated in the figure.

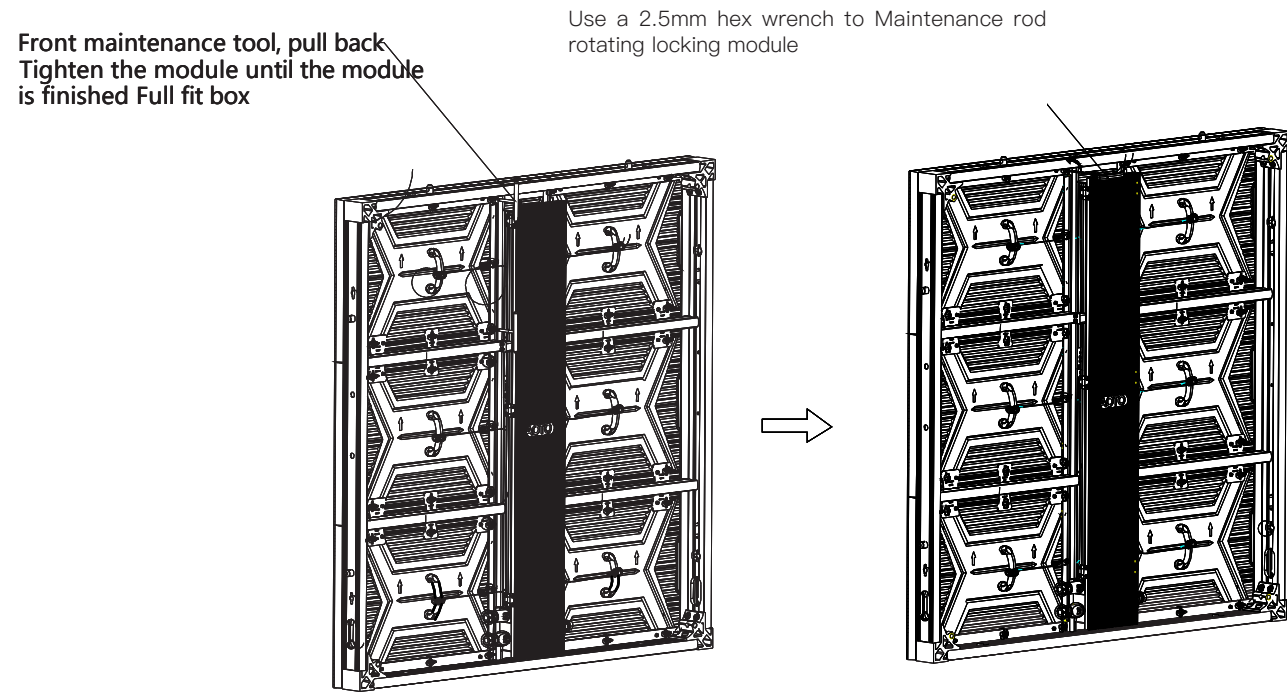

The main process of front maintenance is as follows:

Step 1: Turn off the screen power;

Step 2: Using a 2.5mm hexagonal spanner, insert the maintenance rod through the six front maintenance holes designated for the face shield. Rotate the hexagonal spanner in a counter-clockwise direction, as illustrated.

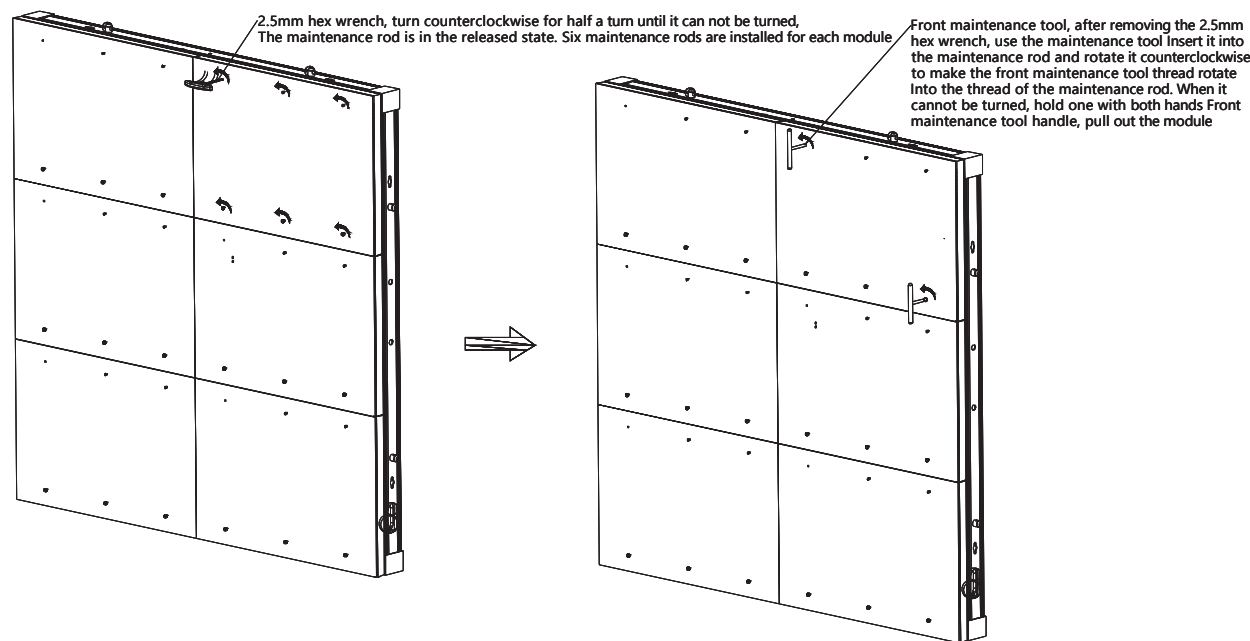

Step 3: After pulling out the module, then removing the safety rope latch on the module, the module can be maintained.

Step 4: Prior to maintaining the inside of the control box, remove all modules from the single box. Inside, you will find the HUB pressure plate. Utilize a cross (Phillips) screwdriver to remove the HUB sealing plate, revealing the vice-HUB installed within. Conduct maintenance as necessary, then restore the installation of the HUB sealing plate. Ensure the screws are securely locked in place to guarantee proper protection, as depicted in the figure.

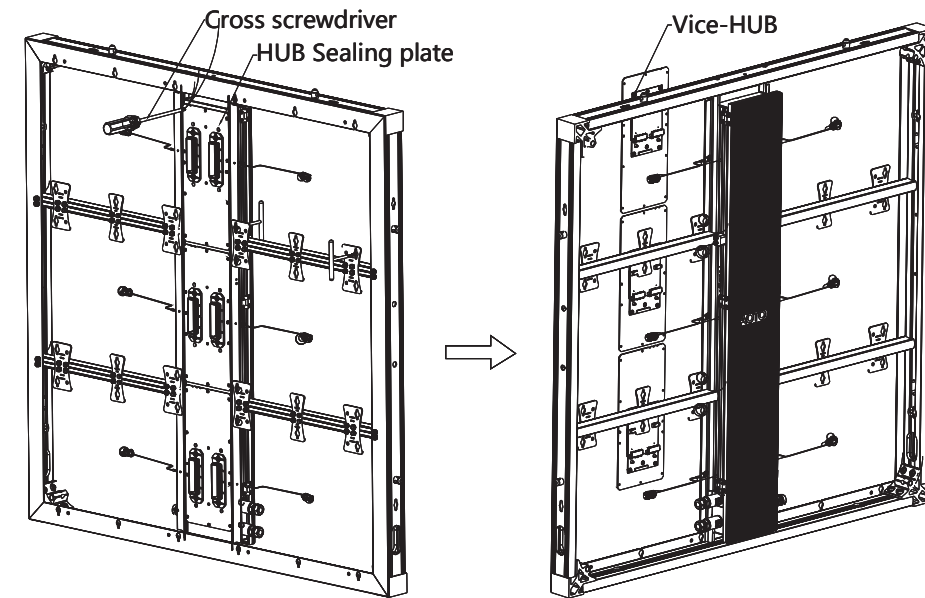

Step 5: Remove the HUB sealing plate to access the power supply and main HUB inside the control box. Utilize a cross screwdriver to maintain the components inside the control box, as depicted.

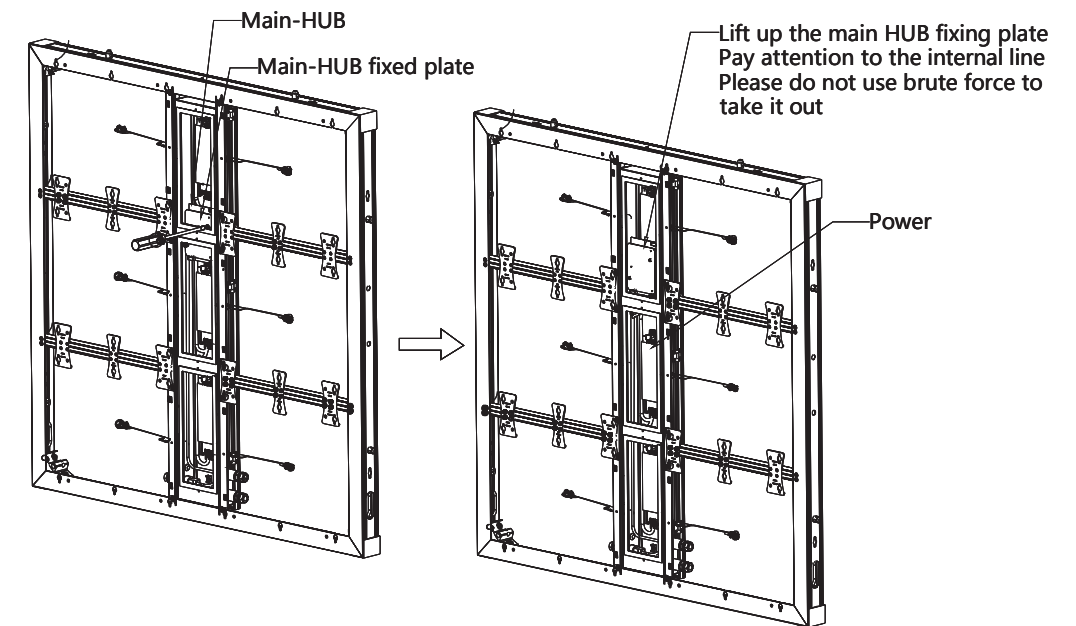

3.3 Cleaning

During use, the product's surface may accumulate dust or other stains, which can affect the display effect of the screen. It's essential to clean the display regularly to ensure optimal display performance.

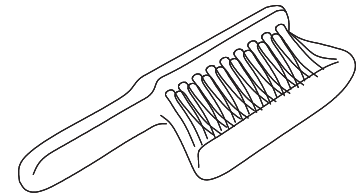

Anti-static brush

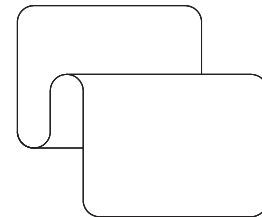

Soft cloth

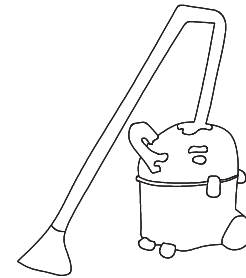

Vacuum cleaner

Cleaning Method for Outdoor Products:

Step 1: Turn off the screen power supply.

Step 2: Use an anti-static soft bristle brush to gently brush away any dirt /stains. For more stubborn stains, you can use a vacuum, a high-pressure air gun, or a high-pressure water gun. (Ensure that the pressure of the air or water gun does not exceed 0.5MPa).

Note: Avoid using industrial grease cleaners during the cleaning process. Only utilize non-reactive, non-corrosive, and non-damaging materials or chemicals that leave no residue. Additionally, refrain from using hard brushes to prevent damage.

3.4 Common Fault Analysis

Fault	Analysis	Solution
Blank screen	Check if the display has been powered on.	Power on
	Check the computer settings to ensure that there is a computer signal output to the capture card (graphics card settings) correctly.	Correctly configure the output mode of the graphics card.
	Check whether the controller or indicator is working properly.	1. Replace the data cable. 2. Replace the controller 3. Replace the scan card
Content Glitching	Check whether the connection diagram is configured correctly	Reconfigure the connection diagram correctly.
The consecutive LED cabinets do not light.	Check whether the first cabinet that does not light up is energized, or whether the indicator light is normal.	1. Check whether the power supply of the cabinet that does not light up is working properly. 2. Check if the first cabinet that does not light up is in good contact with the neighbouring cabinet's network cable. 3. Replace the scanning card of the first unlit cabinet and consult customer service for professional maintenance service.
LED cabinet displays black	1. Product power indicator does not work properly. 2. The product operation indicator is not working properly flashing or always on. 3. The data cable is not properly connected. 4. Product external power cable contact is poor.	1. Check the data cable. 2. Check the external power cable of the product. 3. Replace the switching power supply. 4. Replace the product system scan card.
LED cabinet displays splash screen	1. Data line not connected properly. 2. The product running program is lost.	1. Resend the product configuration parameters in the existing Project file, please consult customer service for detailed operation 2. Replace the product internal scan card; or re-upgrade the control card program, please consult customer service for more details.
LED module display failure	1. LED lamp bead failure, IC failure 2. Module data port is loose, poor contact 3. Loss of colour correction data of the module 4. Bad contact of HUB data port	1. Replace the module and consult customer service for professional maintenance service. 2. Replace the HUB and consult customer service for professional repair service.

4. LED Cabinet packaging removal

4.1 Cabinet packing method

The module is mounted on a frame to form a single cabinet, packed in a wooden box.

A wooden box can be packed with 10 sets of cabinet, the cabinet packaging method is as follows:

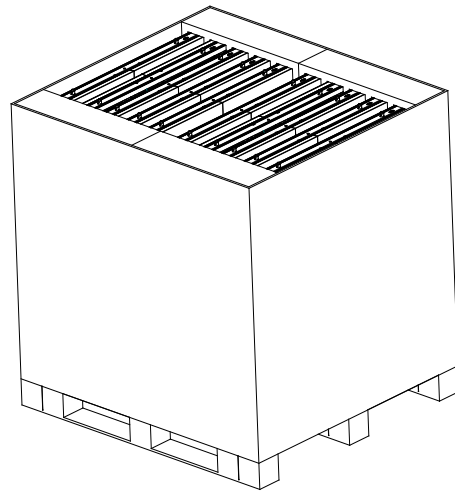

4.2 Cabinet packaging removal method

When removing the packaging, it's crucial to protect the cabinet and prevent any damage to the lamp surface. Below are the main steps for removing the packaging:

Step 1: Cut the packing tape on the outside of the wooden box.

Step 2: Remove the upper lid of the wooden box and the pearl cotton from the upper part of the cabinet.

Following these steps carefully will help ensure the safe removal of the packaging without causing harm to the cabinet or lamp surface.

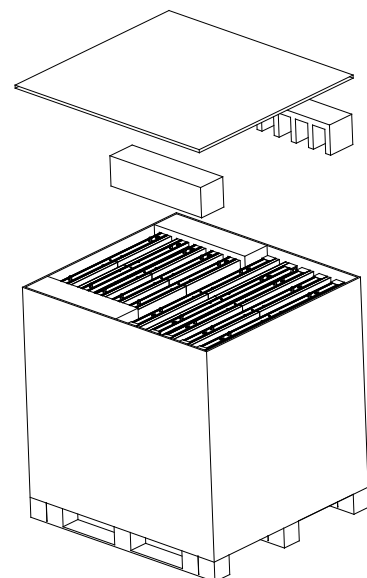

Transportation and delivery

Transportation:

Packed products are suitable for air freight, shipment, and inland transport. Avoid loading in open cabins or compartments during long-distance transportation and refrain from storing in open warehouses during midway transportation. Do not transport with inflammable, explosive, or corrosive articles in the same vehicle or means of transportation. Protect products from rain, snow, or other liquid substances and mechanical damage during transportation.

Storage:

Store products in the original packing box. Maintain warehouse environmental temperature between 20 to 30 , with relative humidity <60%RH and no condensation. Prohibit hazardous gases, inflammable and explosive products, or corrosive chemicals in the warehouse. Ensure no strong mechanical vibration, impact, or magnetic field in the storage area.

Note:

1. Be cautious of extreme temperature changes during transportation, especially in cold weather to prevent condensation. Wait 12 hours before powering on if condensation occurs.
2. Keep storage environment ventilated if the box becomes wet. After drying, store the box back in the original packing.
3. Unpack and inspect deliveries carefully to identify any transportation damage.

Unpacking:

Please pay attention to the following points when unpacking the equipment:

1. Retain original packaging materials for potential future transportation needs.
2. Store documents in a secure location as they are necessary for device debugging.
3. Inspect delivered equipment for any damages incurred during transportation.
4. Verify that the shipment contains all ordered equipment and accessories. Contact customer service if discrepancies or shipping damages are found.
5. Avoid exposing unpacked products to construction site environments for an extended period after unpacking.



Warranty

1. The warranty of the product is governed by the contract mutually agreed upon by both parties.
2. Product failures resulting from the following conditions are not covered by the warranty:
 - Any damage caused by human actions, self-modification, modification, or online burning.
 - Exceeding the effective warranty period or coverage; warranty terms that are inconsistent, altered, or lost.
 - Damage or alterations to the warranty due to force majeure events.
 - Excessive product loss or malfunction due to an unsuitable usage environment.
 - Other failures resulting from causes unrelated to normal wear and tear (normal wear and tear refer to the natural degradation of the product itself, parts, software systems, etc., as stipulated in this document).
3. Newline is not liable for any personal, property, or other damages resulting from the failure of the contents below this document, including but not limited to instructions, steps, specifications, warnings, etc.