

ASSEMBLY INSTRUCTION

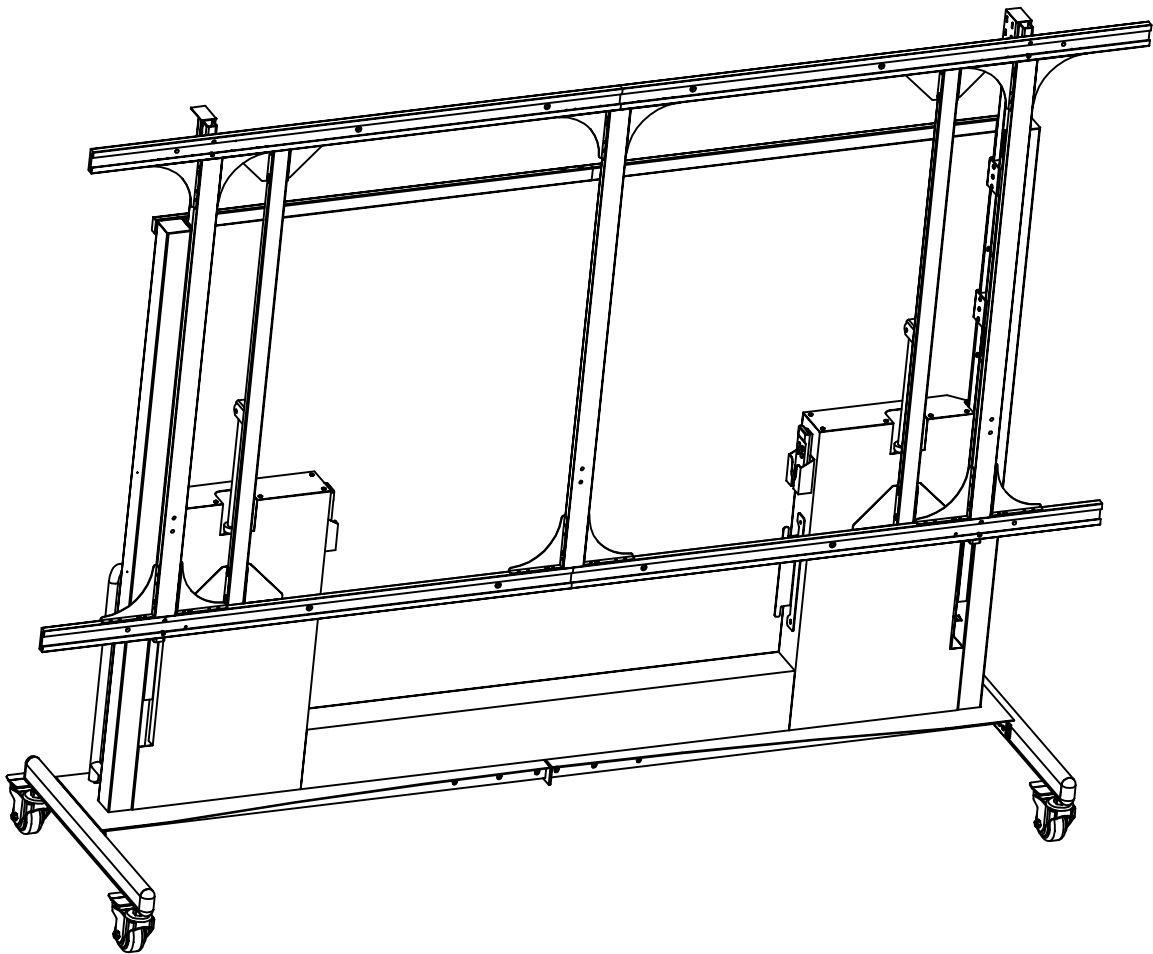

Newline
Motorized Stand for 150" DV One

Hardware List

M8 x 25 Screw

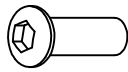

x 38

M6 x 50 Screw

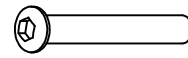

x 20

M5 x 14 Flanged Screw

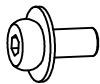

x 88

Spring Cotter Pin

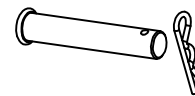

x 4

Step 1 - 12 ea M8x25 screws

Line up bases

Step 2 - 8 ea M8x25 screws

Line up feet with base with longer end facing the front, tighten after Step 3

Step 3 -

Install 4 casters, make sure base is leveled.

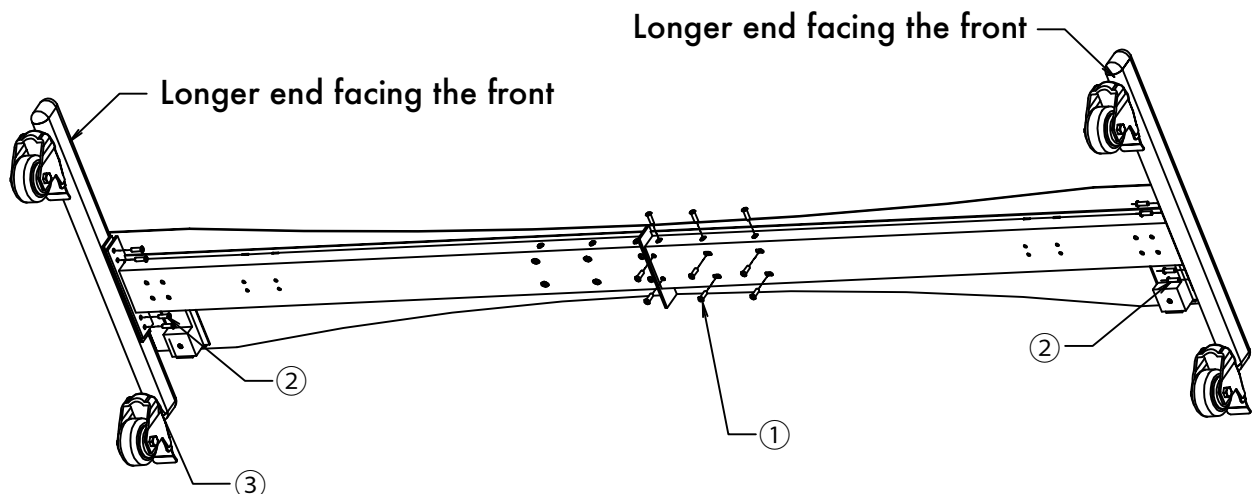

Step 4 - 10 ea M8x25 Screw
Install upright on to base

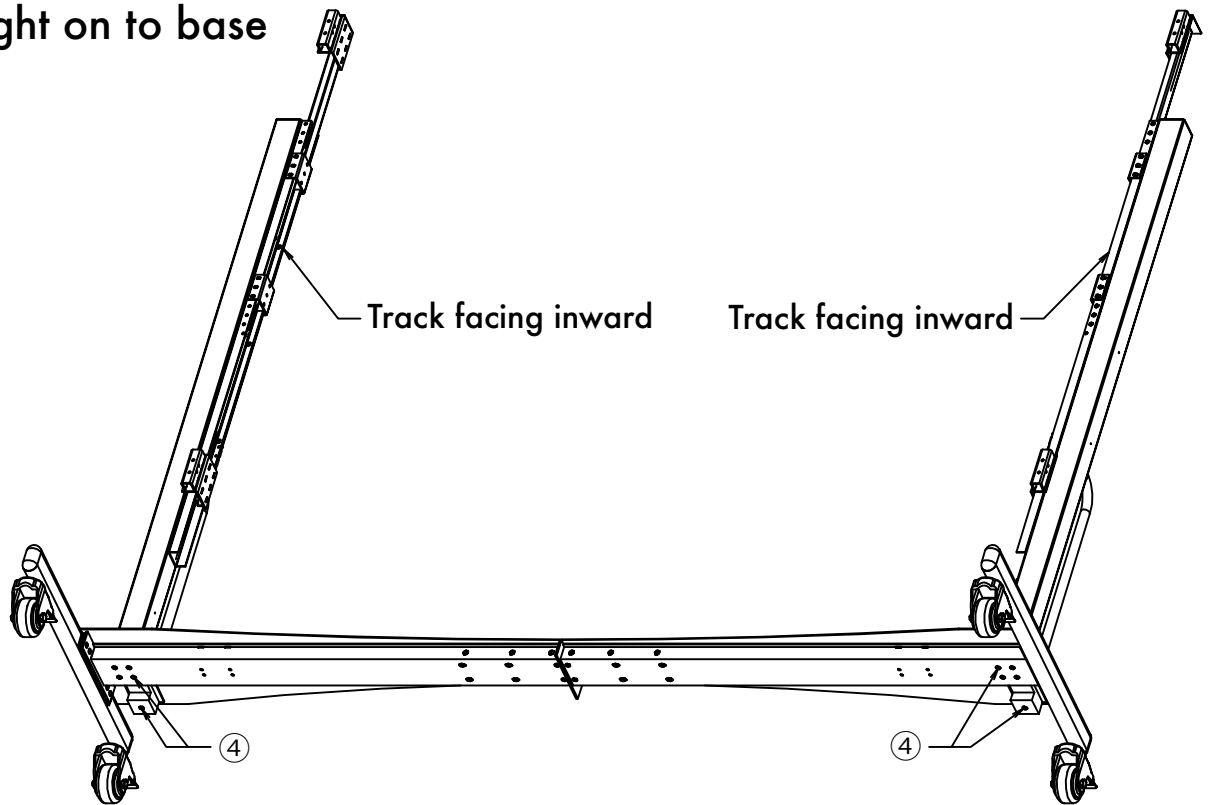

Step 5 - 4 ea M6 x 14 Flange Screw
Connect crossbars

Step 6 - 4 ea M6 x 50 Screw -
Attach crossbar to upright

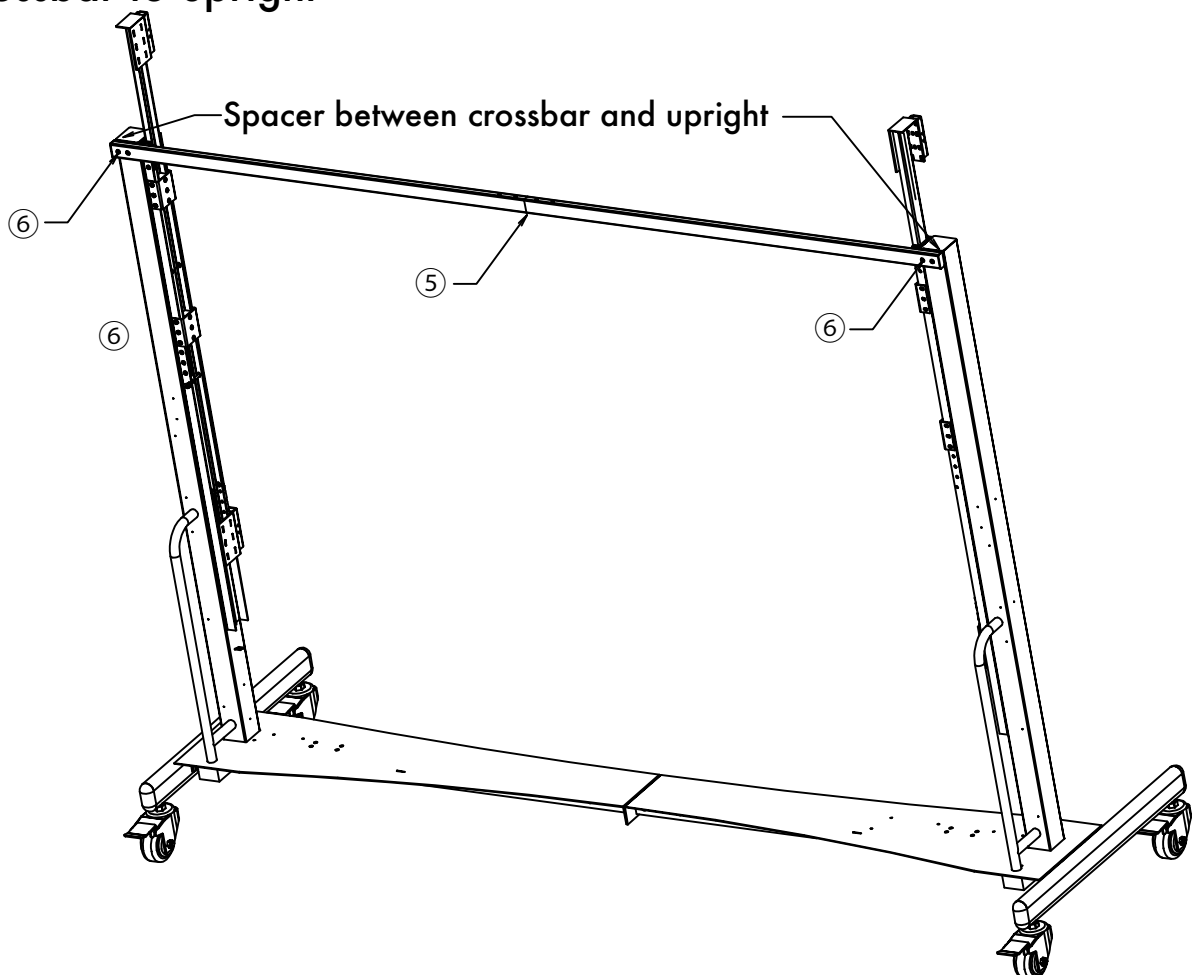

Step 7 - 8 ea M6 x 14 Flange Screw

Connect two sets of crossbars (no notch on lower crossbar)

Step 8 - 8 ea M6 x 50 Screw

Attach crossbar to upright, tighten after Step 9

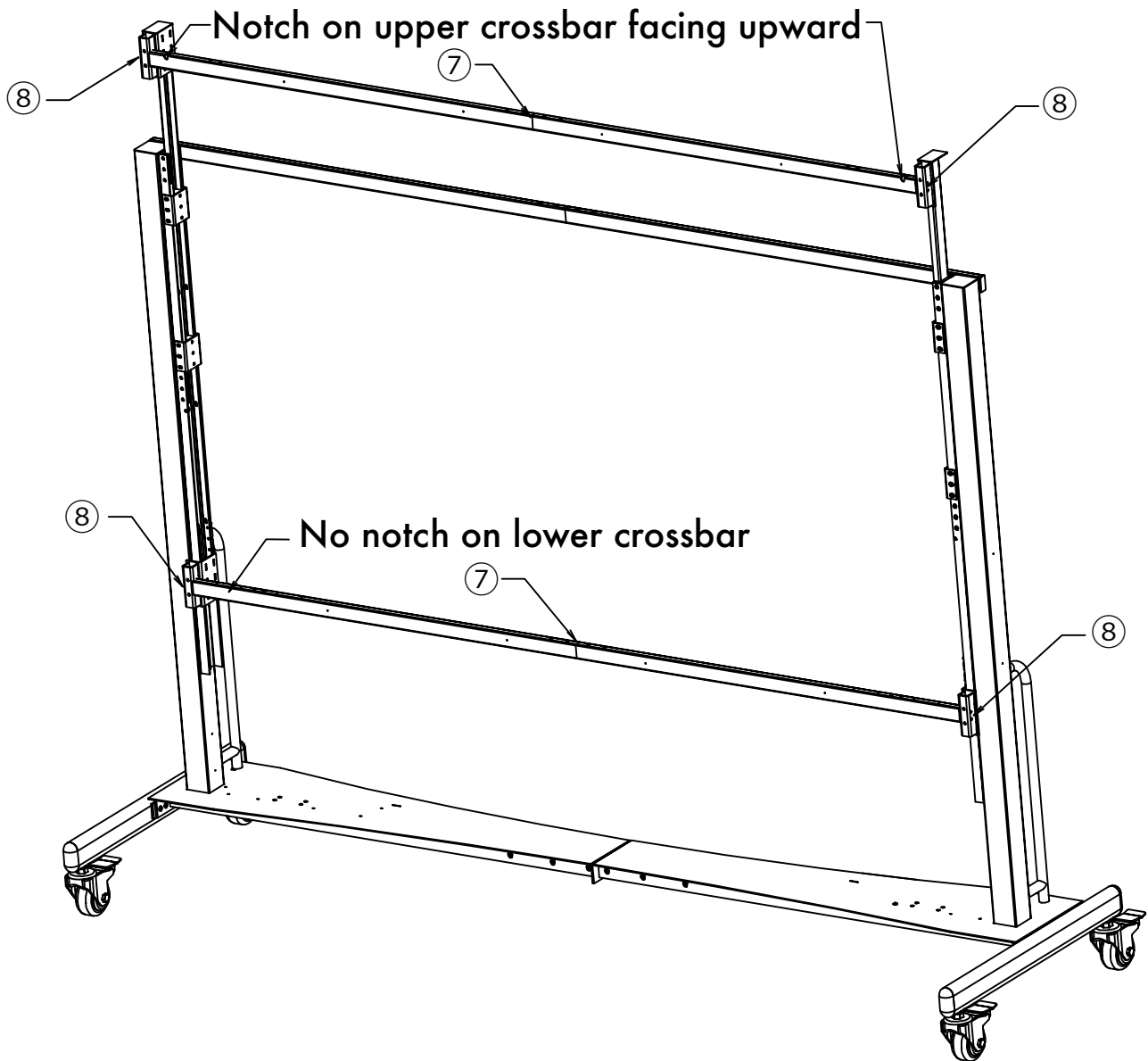

Step 9 - 8 ea M6 x 50 Screw
Attach left and right upright, tighten Step 8

Step 10 - 18 ea M6 x 14 Flange Screw
Attach triangle brackets to upright and corssbar

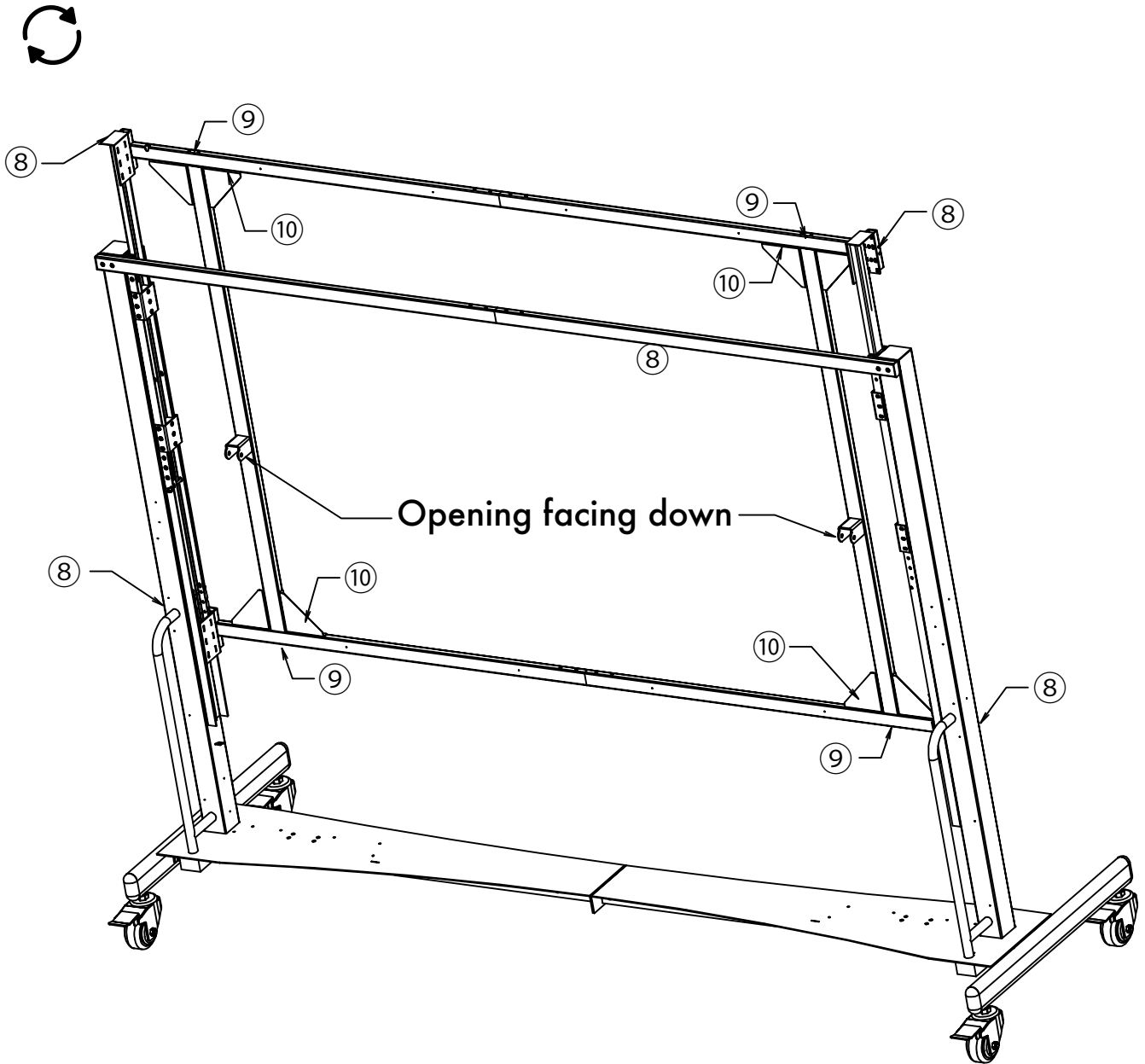

Step 11 - 16 ea M6 x 14 Flange Screw
Attach motor housing, tighten after Step 12

Step 12 - 6 ea M6 x 14 Flange Screw
Attach center housing, tighten Step 11

Step 13 - 8 ea M8 x 25 Screw
Attach motor bracket

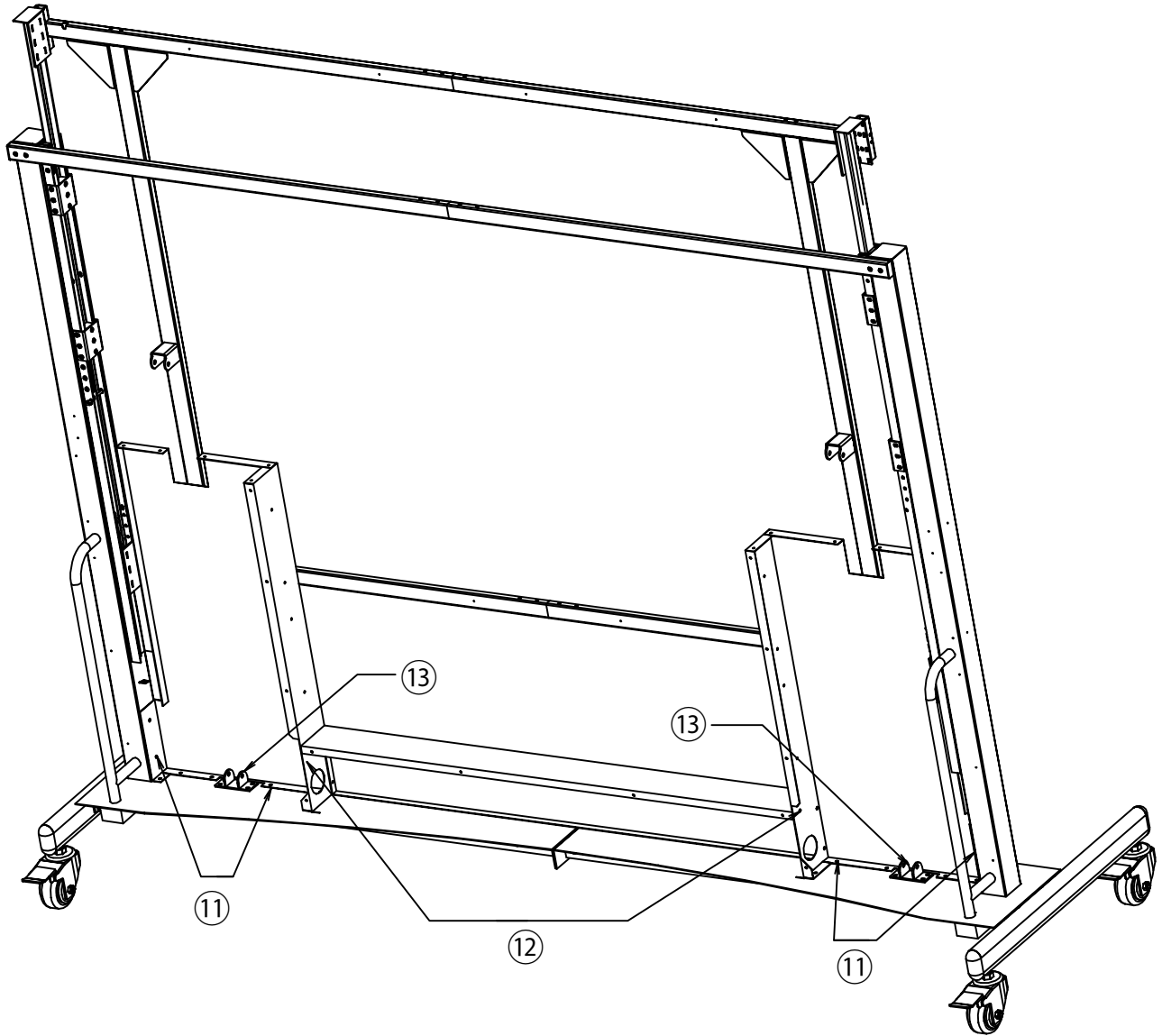

Step 14 - 4 ea Spring Cotter Pin
Install and secure motor, test run after installed

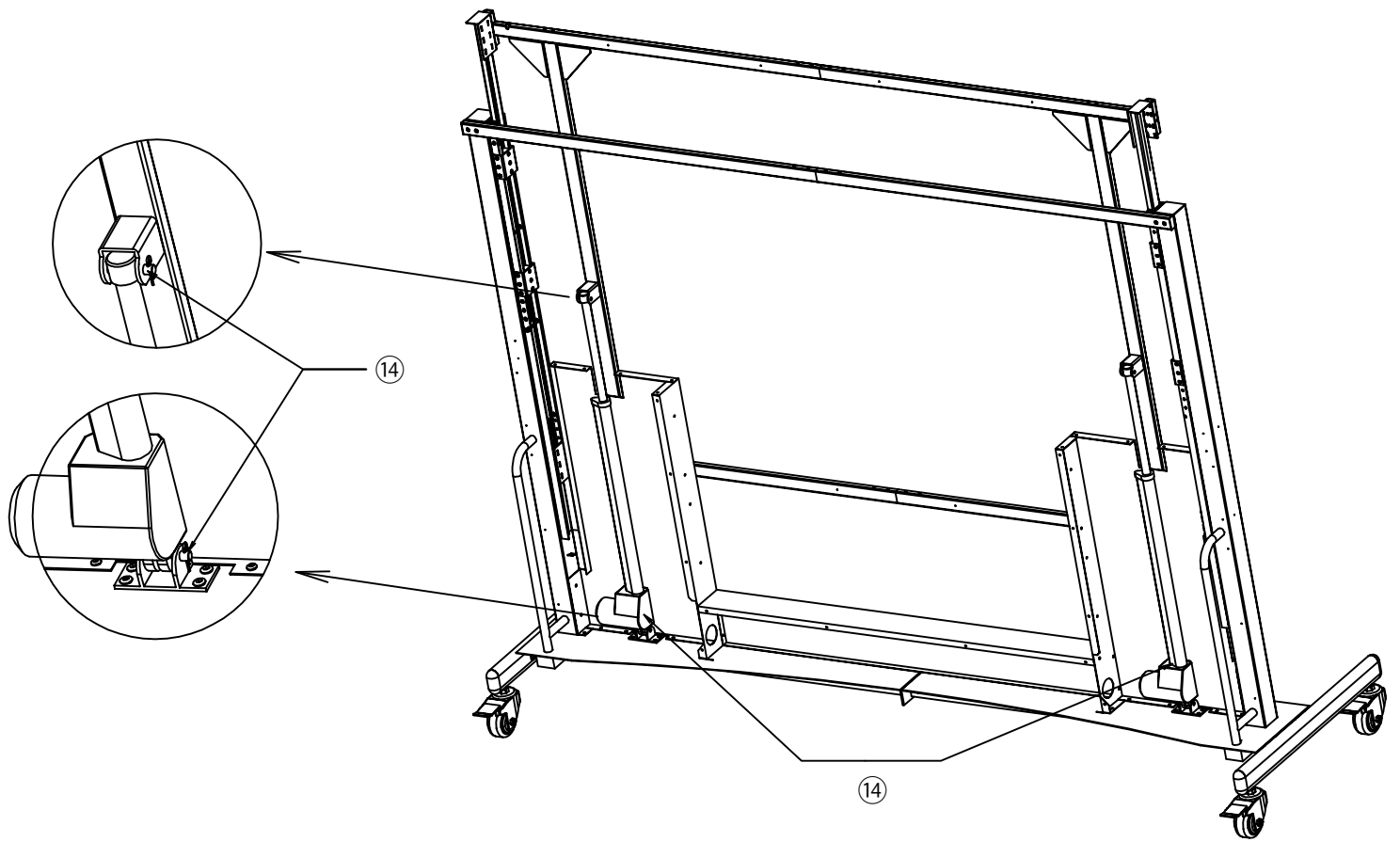

Step 15 - 2 ea M6 x 14 Flange Screw
Attach motor housing cover

Step 16 - 4 ea M6 x 14 Flange Screw
Attach center housing cover

Step 17 - 2 ea M6 x 14 Flange Screw
Attach remote control holder

Step 18 - 2 ea M6 x 14 Flange Screw
Attach cord winder

