

STV+ 115" Wall Mounting Bracket Installation Guide



Dear customer: Before installation, please read the installation instructions carefully. Product damage caused by personal actions is not covered by the warranty. If there are any problems encountered during the installation process or if the after-sales department needs to come on-site for installation, please contact us.



PAP
Raccolta Carta



FR
Cet appareil, ses accessoires, piles et cordons se recyclent

REPRISE À LA LIVRAISON
OU

À DÉPOSER EN MAGASIN
OU

À DÉPOSER EN DÉCHÈTERIE

Points de collecte sur www.quefairedesdechets.fr
Privilégiez la réparation ou le don de votre appareil !

Installation Instructions:

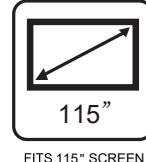
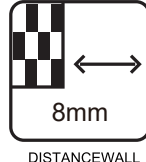
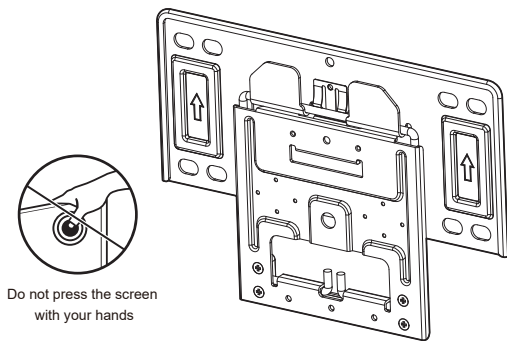

- To install the bracket properly, please read the installation guide carefully.
- Please ask authorized installation company to install the bracket.
- If you are not clear with the installation guide, please contact us.
- The illustrations in this manual are for reference only, please refer to the actual product.

Installation Instructions:

1. When installing the screen set and this wall mounting bracket, at least two professionals are required to perform all the installation operations. Do not attempt to install by yourself, so as to avoid personal injuries caused by misoperations.
2. When installing, the installation position should be specified by professionals, so that its strength can support the gross weight of the screen set and the bracket for long time. Also, measures should be taken to make sure that the installation position has enough strength to bear outside forces. The hanging points should be stressed on the wall directly. Do not install at positions without enough strength, such as decorative materials or cardboard pasted on the wall.
 - The recommended installation distance is 2.5-4.5 meters, and the installation height is recommended to be at the same horizontal line as the center of the screen and the line of sight when sitting for viewing. (approx. 8.2021-14.7638 ft)
 - To prevent accidental damage to the screen set and personal safety accidents, please avoid to install the bracket at positions that children are easy to touch as possible as you can.
3. The bracket should be installed on vertical surface. Avoid to install on gradient surface or on the top of the room, otherwise the screen set may fall off and cause personal injuries.

4. If any screws or parts that assembled were loose or lost, switch off and unplug the screen set, and contact professionals to repair.
5. When installing the bracket, avoid places where are within force electricity or strong magnetic field, avoid positions where are easy to cause noise or vibration, and avoid places where flammable gas is easy to leak.
6. To watch screen programs normally and avoid eyestrain caused by direct strong light and backlighting, avoid to install the bracket in places where there is direct strong light.
7. To prevent fire, avoid to install the bracket in places with bad conditions, such as heavy smoke, strong wind, moisture or high-temperature heat source.
8. When installing, make sure the metal parts and screws are connected tightly, so as to prevent the screws from loosening to cause the screen set falling off and personal injuries.
9. Read and understand this installation guide seriously, and follow all the instructions strictly. Our company does not bear responsibility for any damage and loss caused by improper installation and operations.

This mount fits for screen size : 115"

Part list:

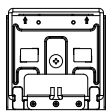

Machine bracket X4

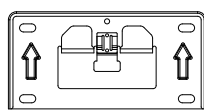

Wall bracket X4



Expansion plug X16



Wood grain screw X16



Pad X8



M4 screw X4

Assembly steps:

1. Take out four machine brackets and use the M8 screws that come with this bracket to fix the complete machine brackets into the four VESA holes near the top of the screen, ensuring that the installation height of the four brackets is the same and that the complete machine brackets are securely locked to the screen.

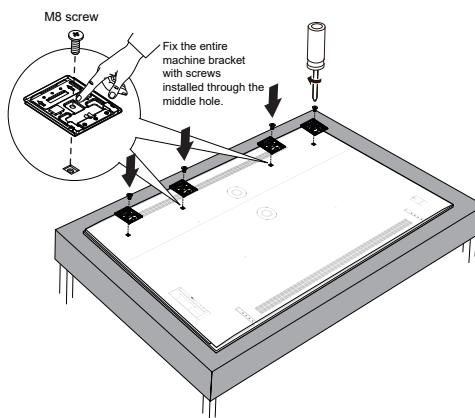

During installation, the arrow points upwards towards the screen.

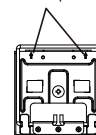

Attention:
The whole machine bracket should be fixed to the whole machine as neatly as possible, and the example of whether it is installed in place is as follows:

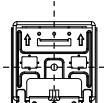
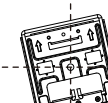

2. Select the appropriate wall installation location, use positioning cards to mark the fixed position of the wall bracket on the wall, and drill holes on the wall according to the actual hole spacing of the screen VESA(As shown in Figure 3 below).
 Attention: Use a spirit level to adjust the position of the positioning card during installation to ensure that the installation position is horizontal.

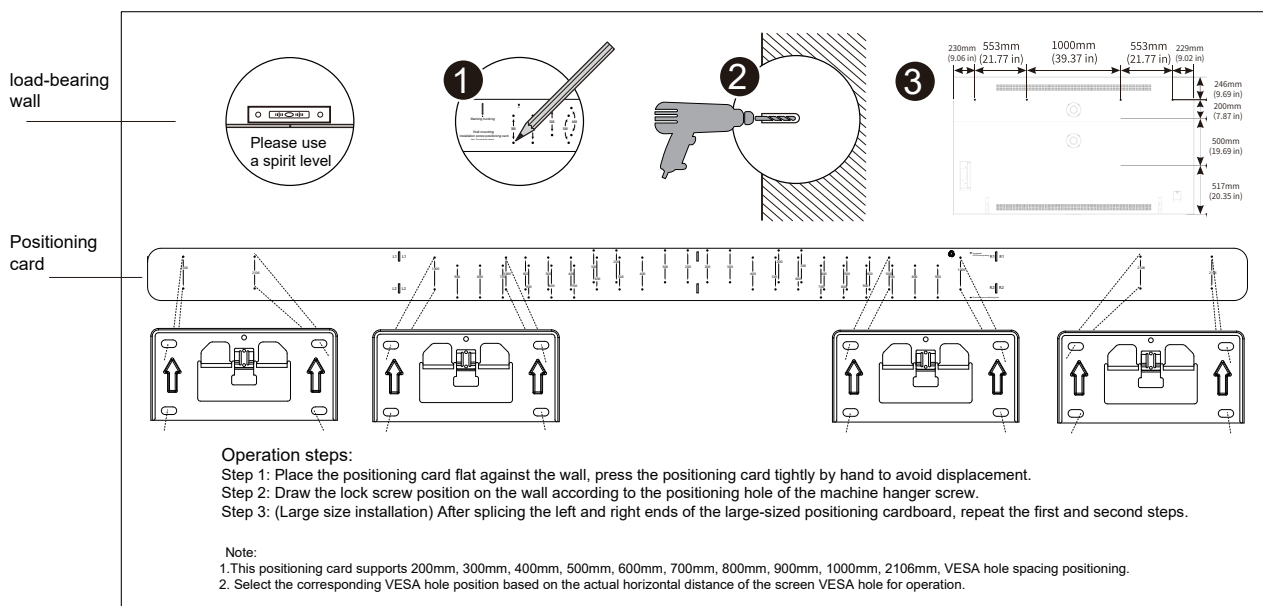

3. Use 16 wood grain screws and 16 expansion rubber plugs to secure the four wall brackets to the wall.
 Attention: During installation, pay attention to the wall bracket with the arrow pointing upwards towards the screen.

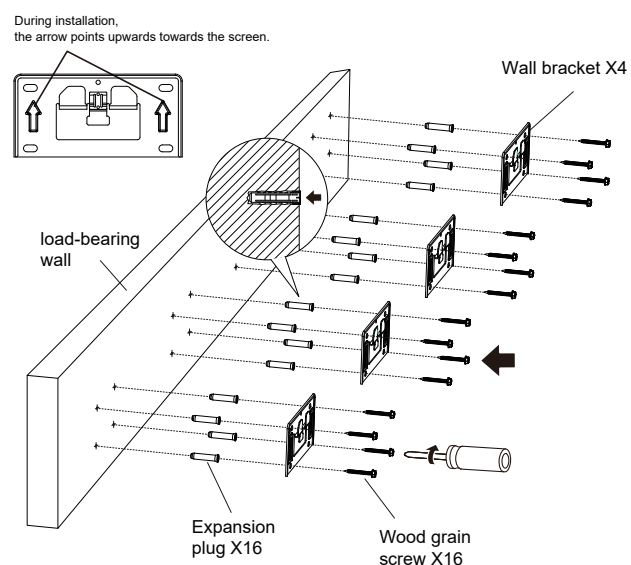

4. Open the steel wires of the four machine brackets at a certain angle (ensuring that the angles of the four wires are as consistent as possible), and take out four pads and paste them onto the bottom of the machine near the edge (the pads can be pasted onto the wall according to the actual situation).

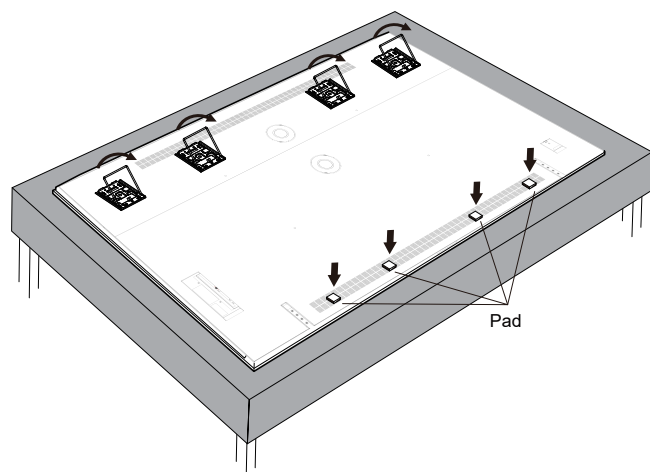

5. Insert the steel wire of the complete machine bracket into the hook of the wall bracket, please hold the lifting handle to gently lift the machine, and push it towards the wall to ensure that the complete machine bracket is attached to the wall bracket. The installation is complete. If you need to unplug or plug in the power or signal cable, please turn off the power first and proceed as shown in the figure on the right.
 Attention: At least two or more people should operate simultaneously to avoid damaging the screen, and personal safety.

