

16	17	18	19	20
VERSION	PROPOSER	REASON	MARK	REVISION
				DATE
				SIGN

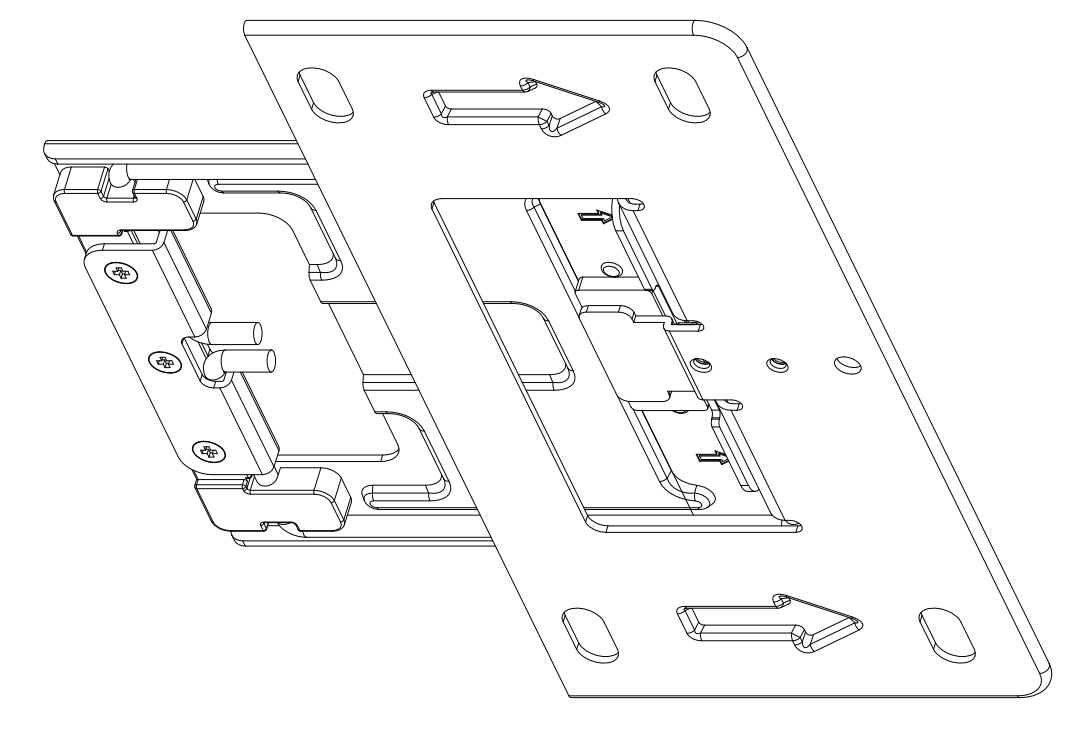
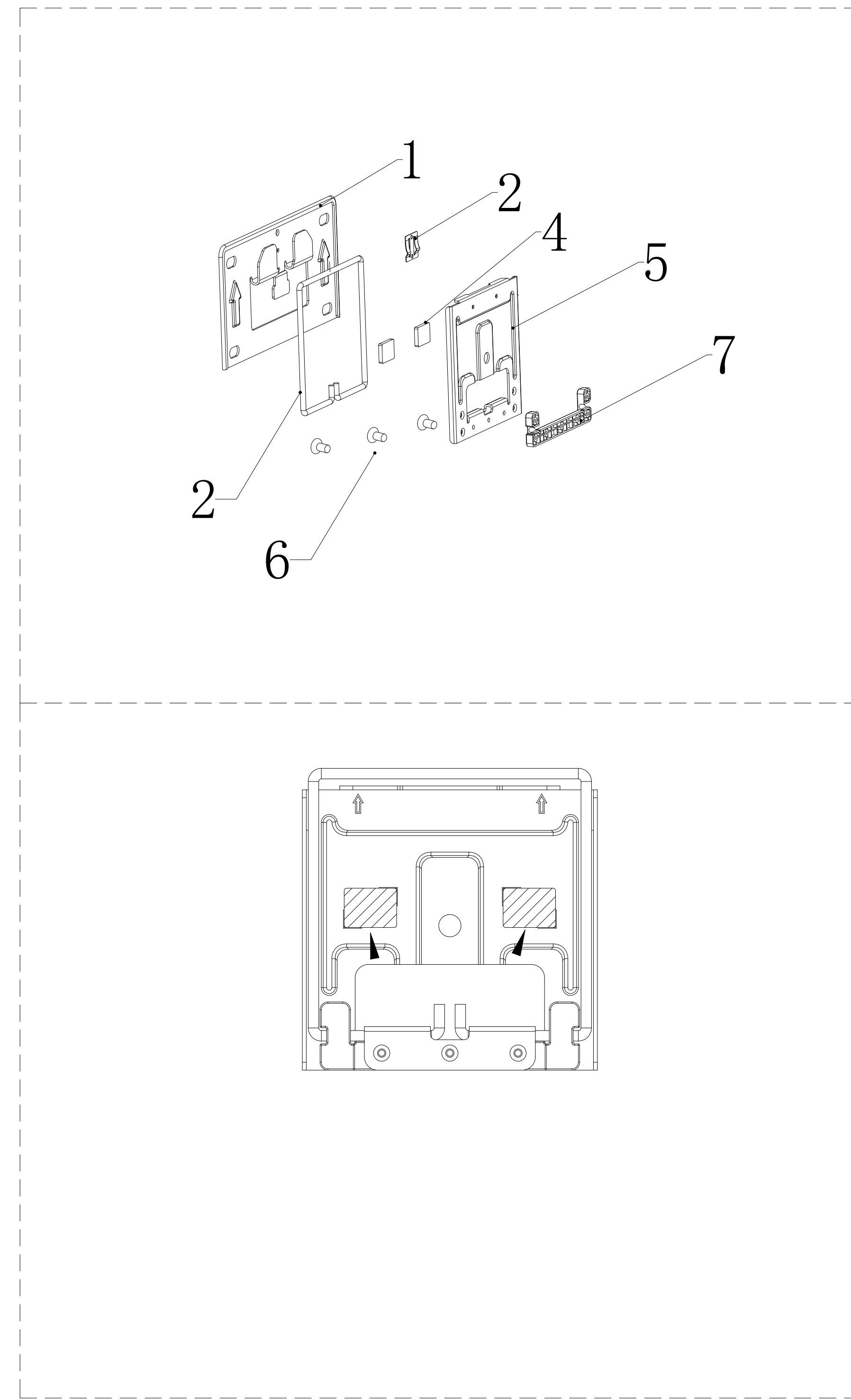
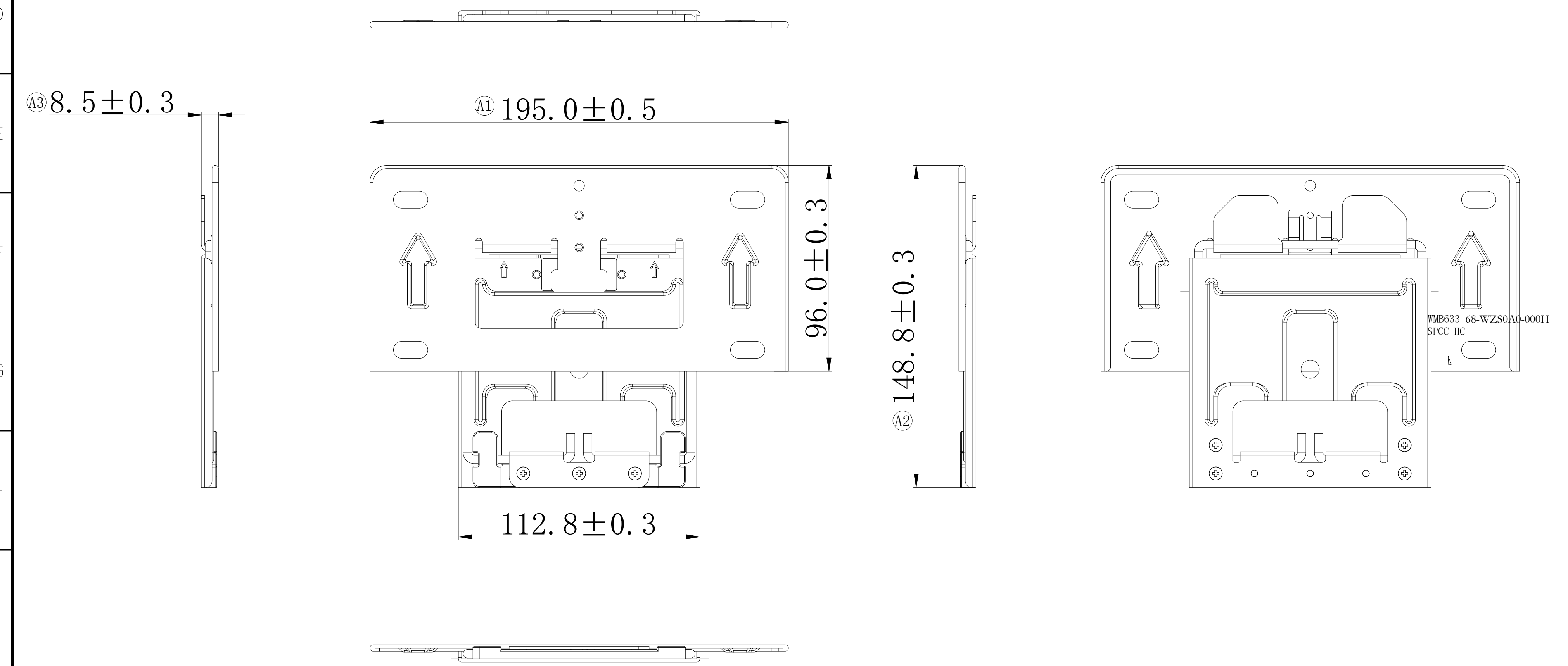

GENERAL LINEAR TOLERANCE				
STEP	1	2	3	SELECT LEVEL
0~25	0.05	0.1	0.2	2
25~100	0.1	0.15	0.2	
100~200	0.15	0.2	0.4	2
200~400	0.2	0.3	0.6	
400~700	0.3	0.4	1.0	2
700~1000	0.4	0.4	1.2	
1000~	0.5	0.6	1.5	2
ANGLE	±0.5°	±1.0°	±1.5°	

PART NUMBER		68-WZS0A0-000H			
PART DESCRIPTION		CHECKED	DATE		
MODEL NAME		DESIGNED	DATE		
UNIT		SCALE	PROJECT	SIZE	SHEET NUMBER
MM	1:1		A3	1 OF 3	20240729
					REVISION
					V1.0

16	17	18	19	20
VERSION	PROPOSER	REASON	MARK	REVISION
				DATE
				SIGN

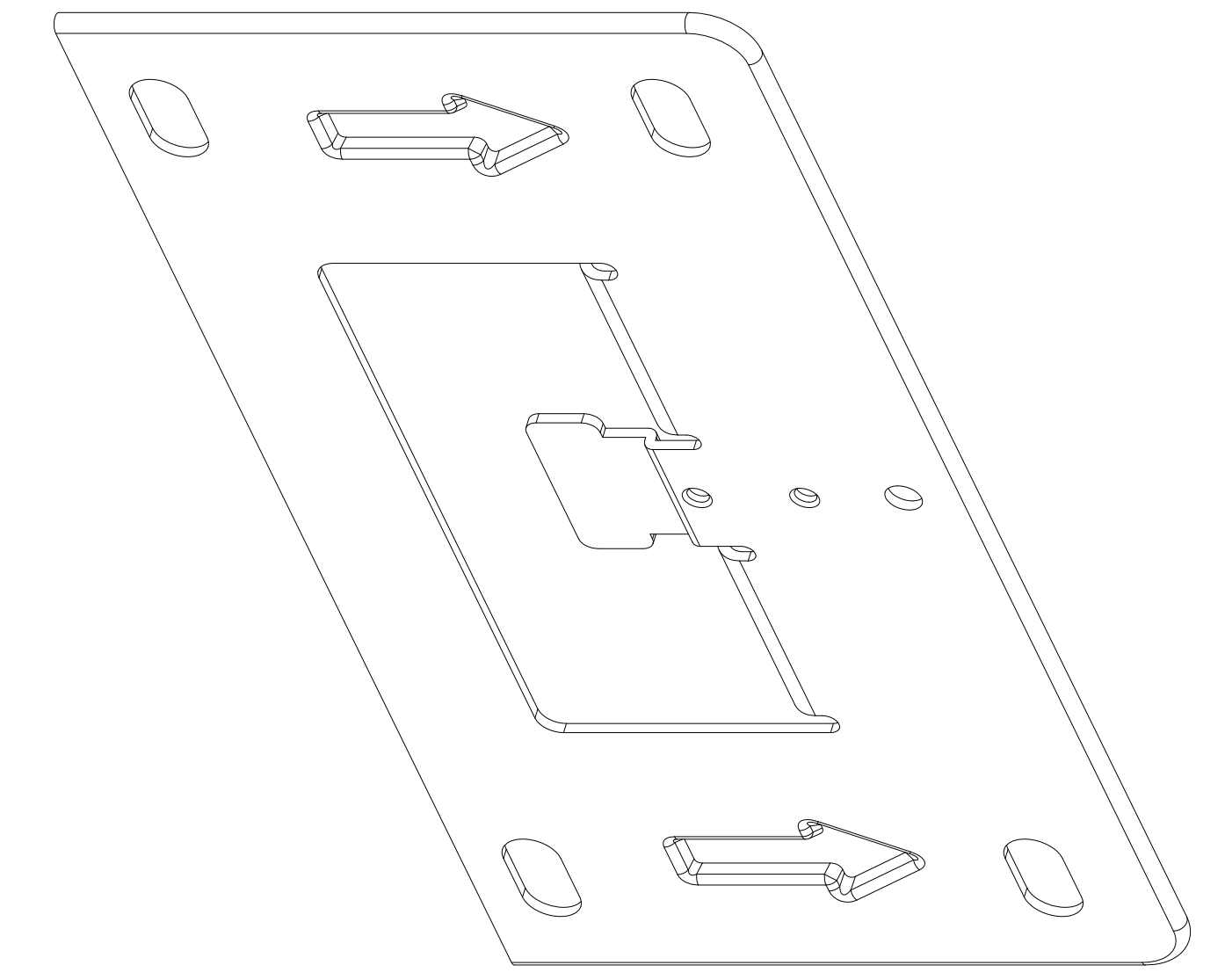
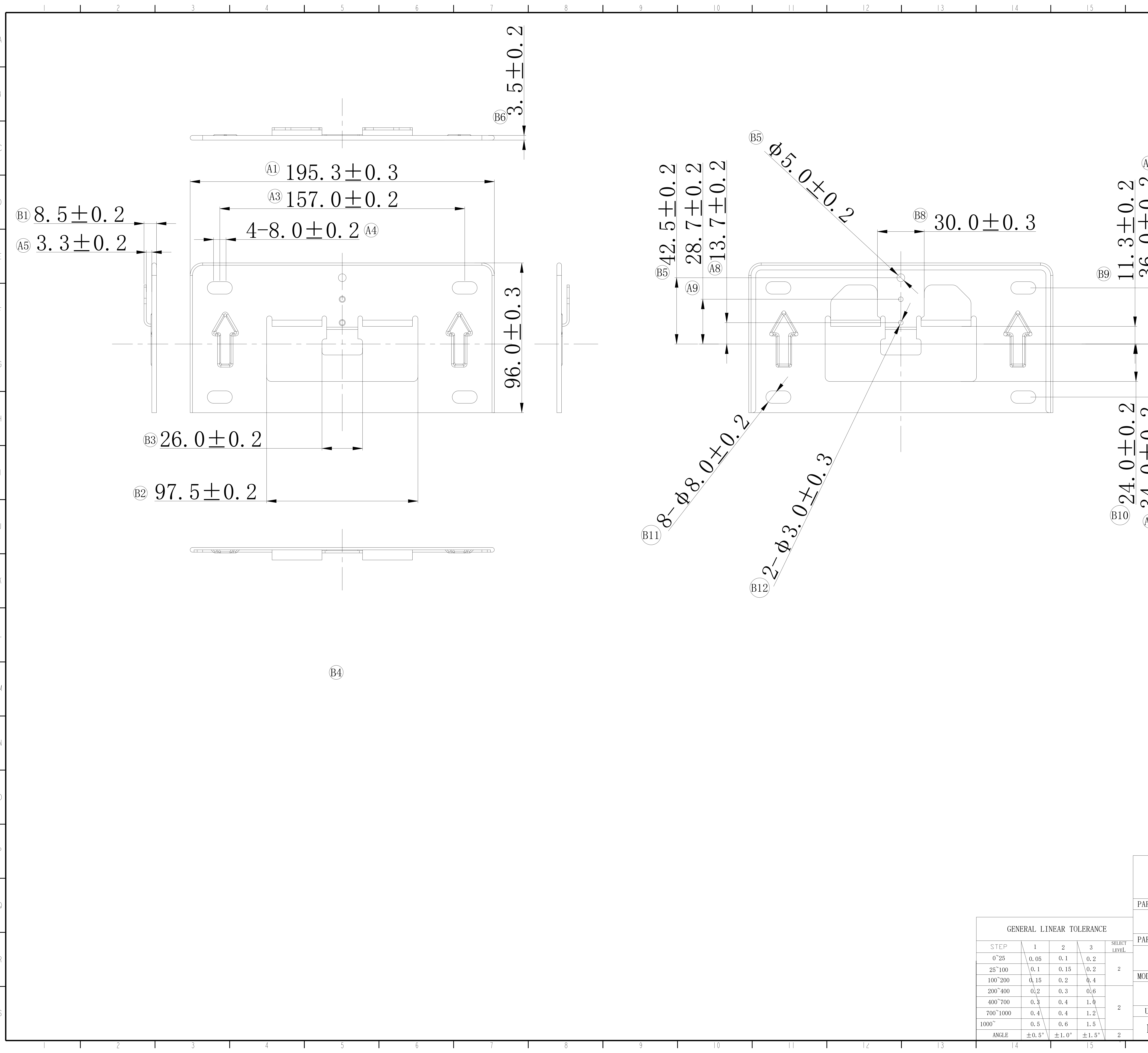

GENERAL LINEAR TOLERANCE				
STEP	1	2	3	SELECT LEVEL
0~25	0.05	0.1	0.2	2
25~100	0.1	0.15	0.2	
100~200	0.15	0.2	0.4	2
200~400	0.2	0.3	0.6	
400~700	0.3	0.4	1.0	2
700~1000	0.4	0.4	1.2	
1000~	0.5	0.6	1.5	2
ANGLE	±0.5°	±1.0°	±1.5°	

PART NUMBER		APPROVED		DATE	
68-WZS0A0-1					
PART DESCRIPTION		CHECKED		DATE	
MODEL NAME		DESIGNED		DATE	
				20240729	
UNIT	SCALE	PROJECT	SIZE	SHEET NUMBER	REVISION
MM	1:1	PROJECT	A3	1 OF 3	V1.0

16	17	18	19	20
VERSION	PROPOSER	REASON	MARK	REVISION

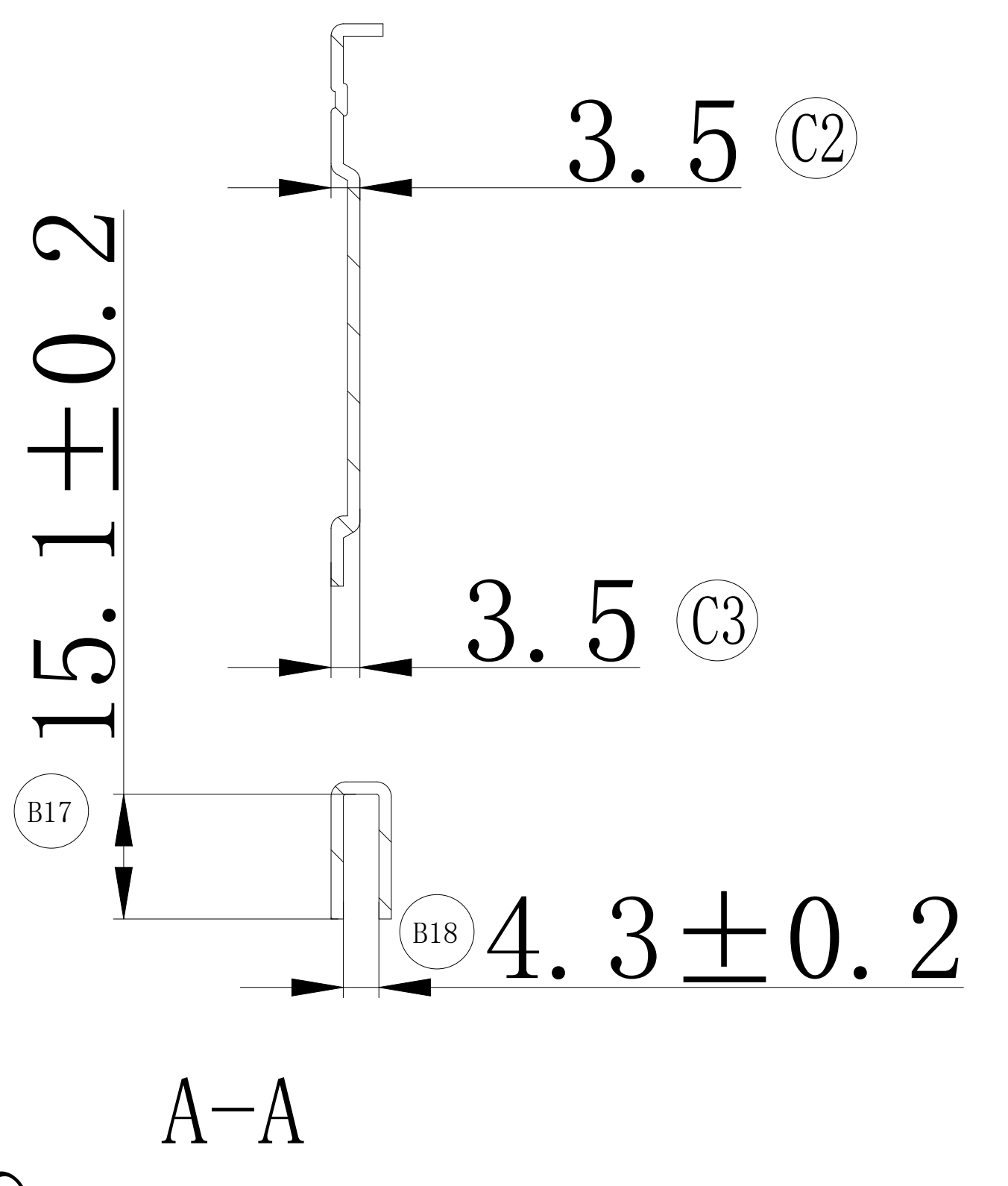
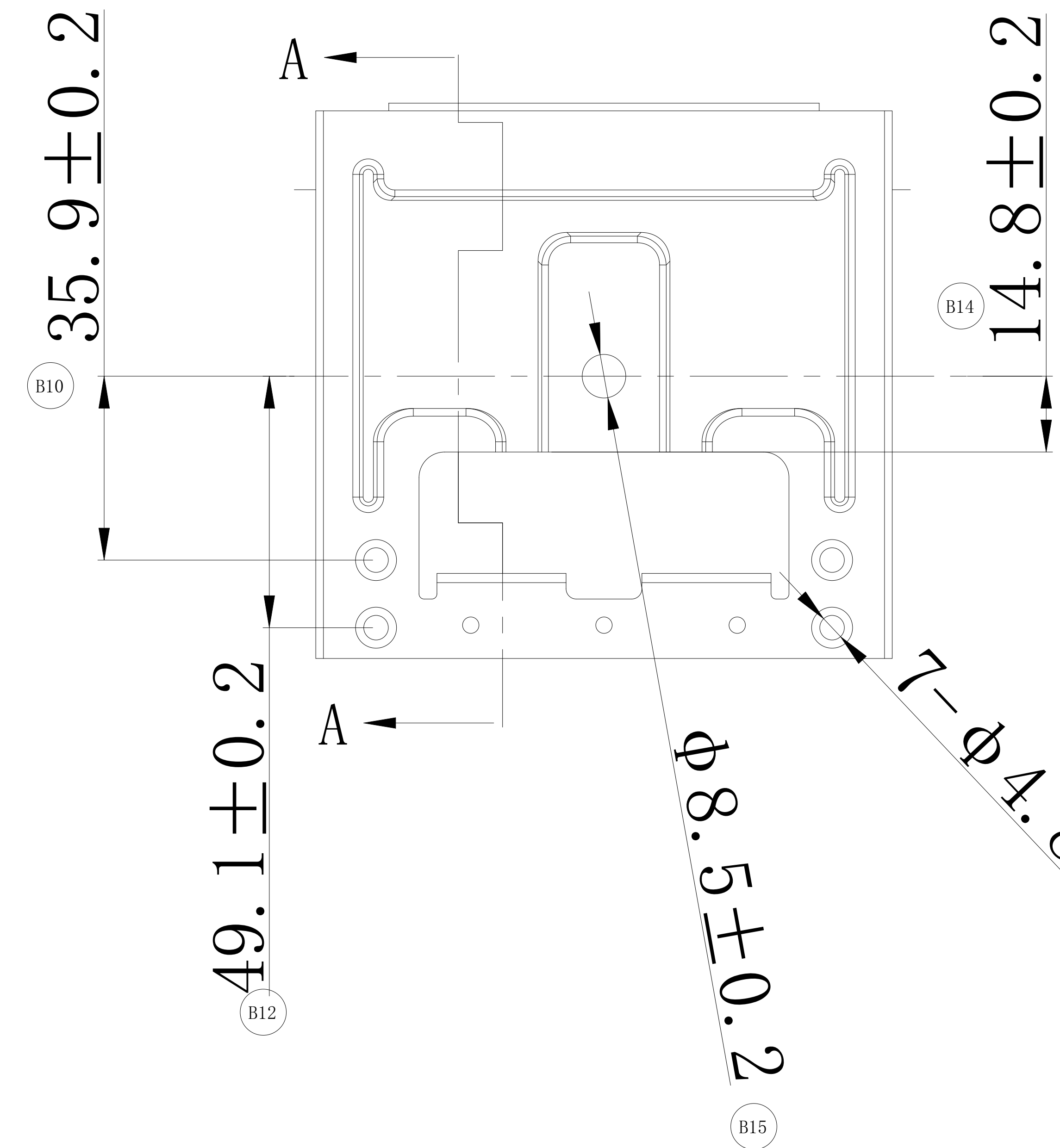
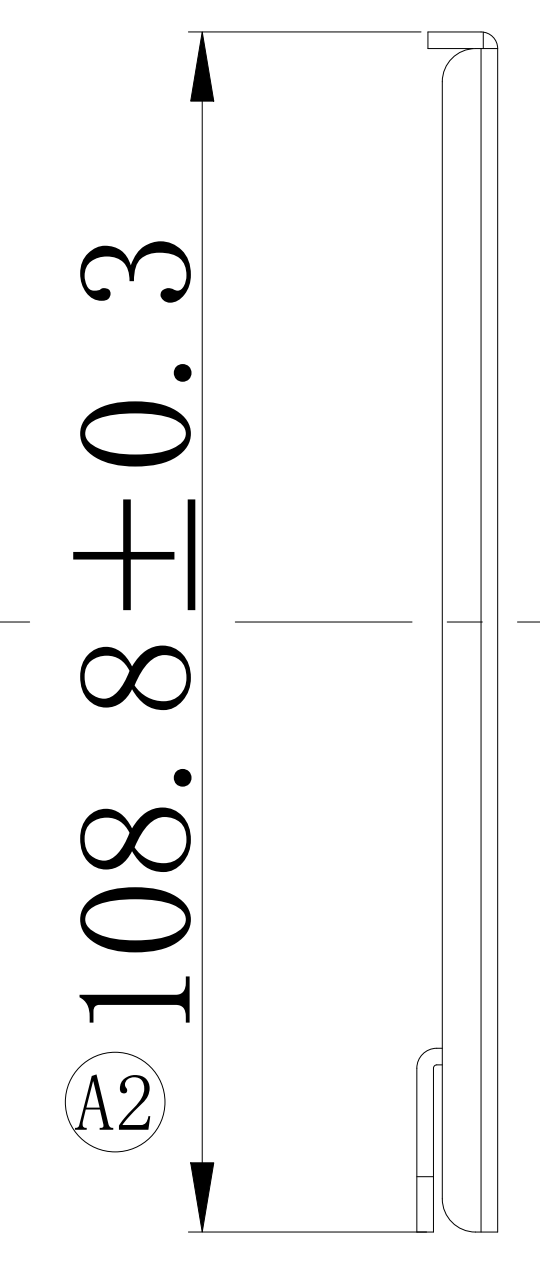
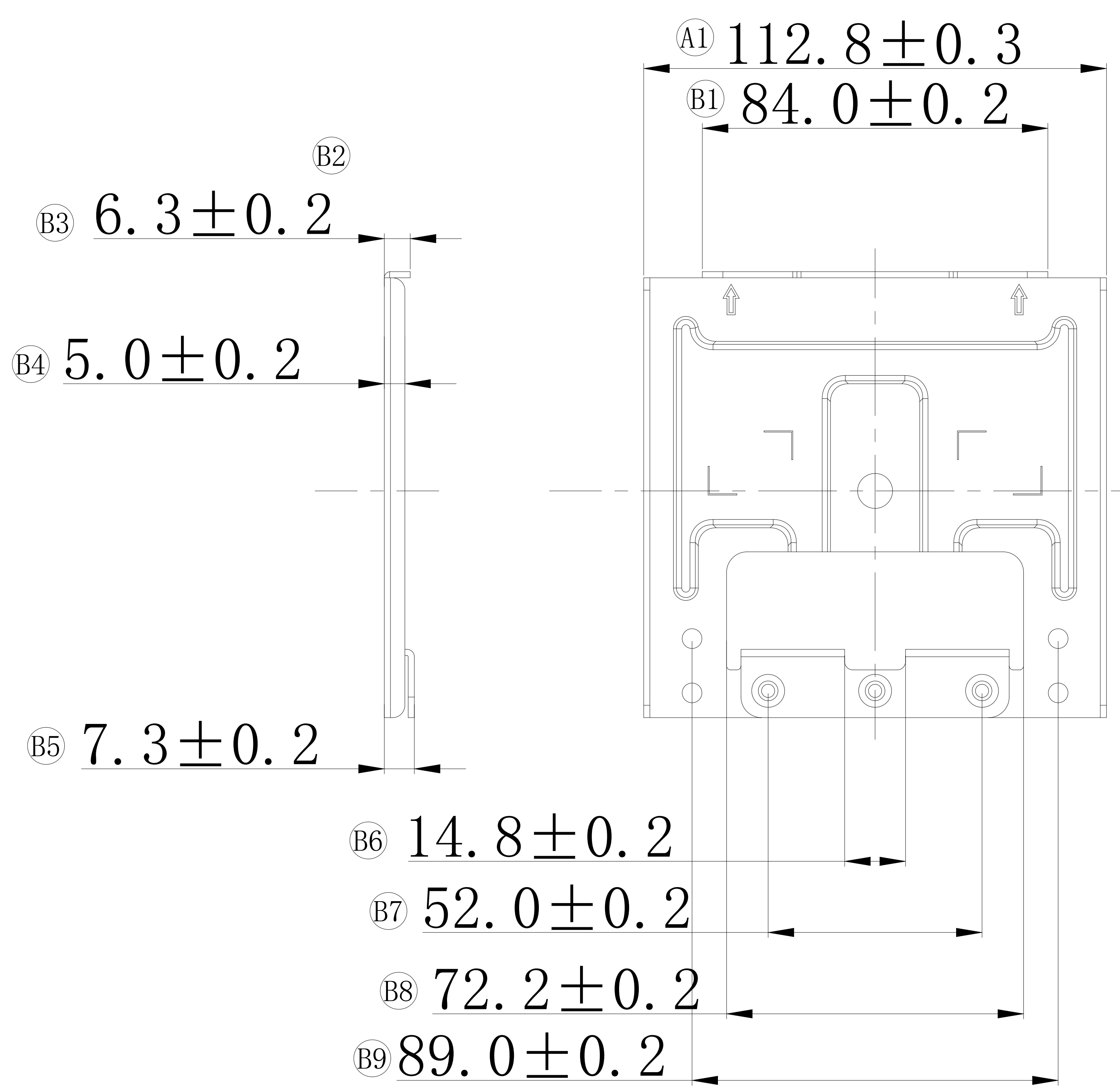
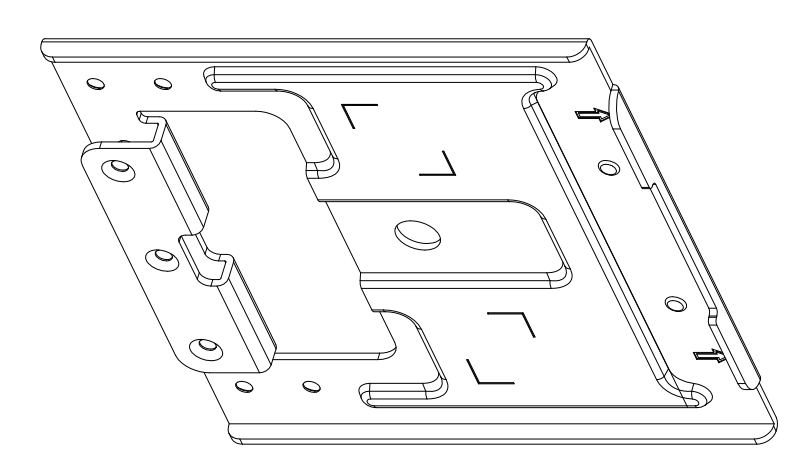
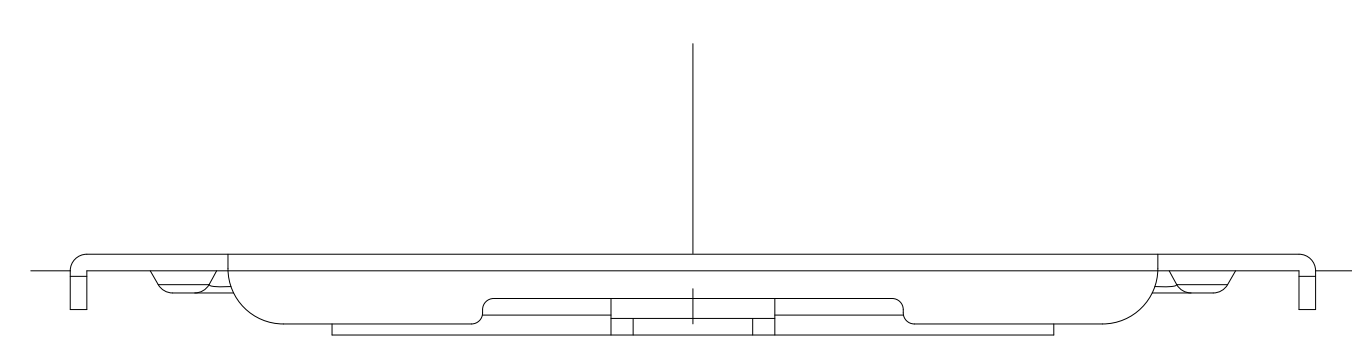

$\phi 8.5 \pm 0.2$   
 $7 - \phi 4.8 \pm 0.2$

GENERAL LINEAR TOLERANCE				
STEP	1	2	3	SELECT LEVEL
0~25	0.05	0.1	0.2	2
25~100	0.1	0.15	0.2	
100~200	0.15	0.2	0.4	2
200~400	0.2	0.3	0.6	
400~700	0.3	0.4	1.0	2
700~1000	0.4	0.4	1.2	
1000~	0.5	0.6	1.5	2
ANGLE	$\pm 0.5^\circ$	$\pm 1.0^\circ$	$\pm 1.5^\circ$	

PART NUMBER		APPROVED		DATE	
68-WZS0A0-2					
PART DESCRIPTION		CHECKED		DATE	
MODEL NAME		DESIGNED		DATE	
				20240729	
UNIT	SCALE	PROJECT	SIZE	SHEET NUMBER	REVISION
MM	1:1		A3	1 OF 3	V1.0

16	17	18	19	20
VERSION	PROPOSER	REASON	MARK	REVISION

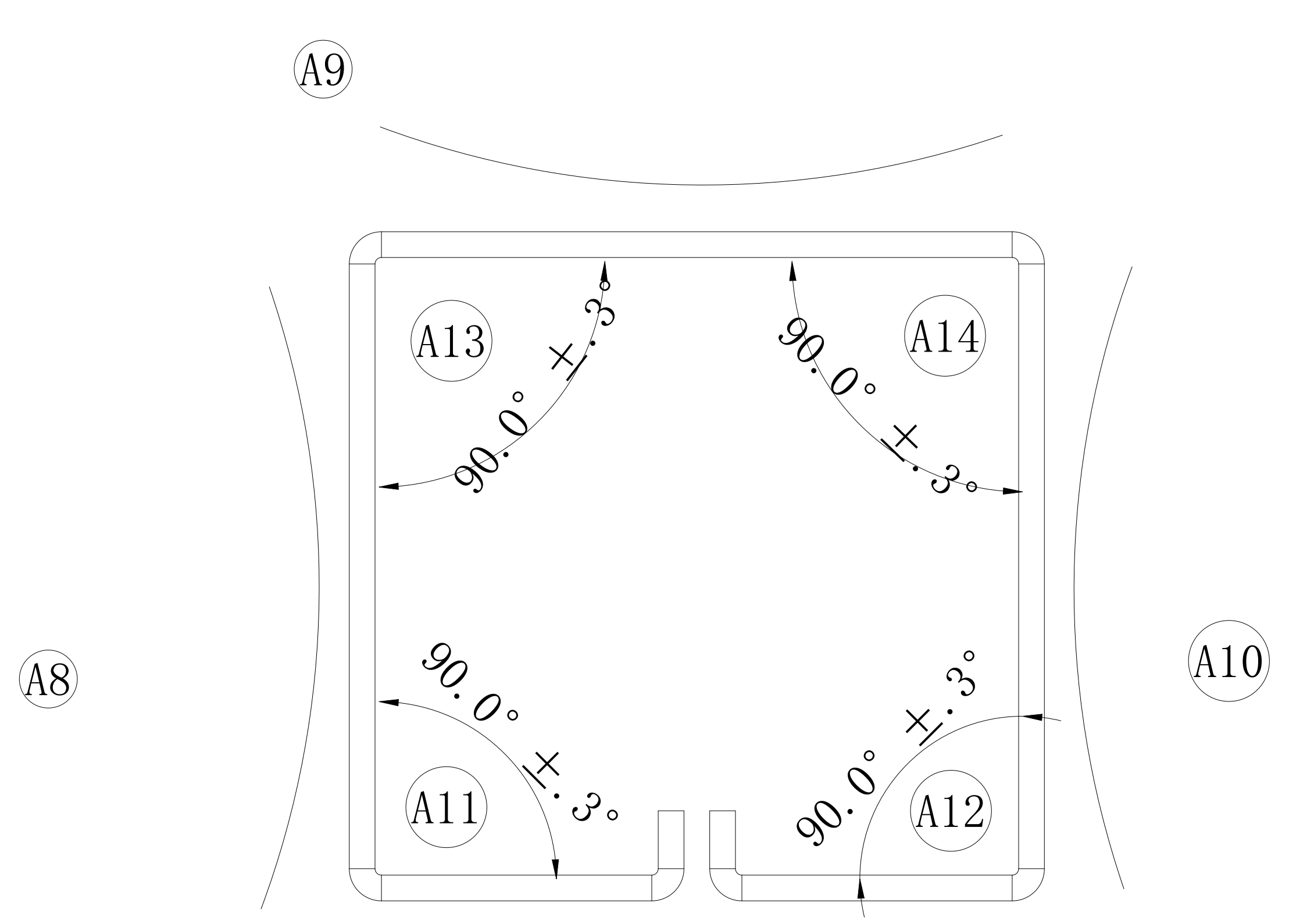
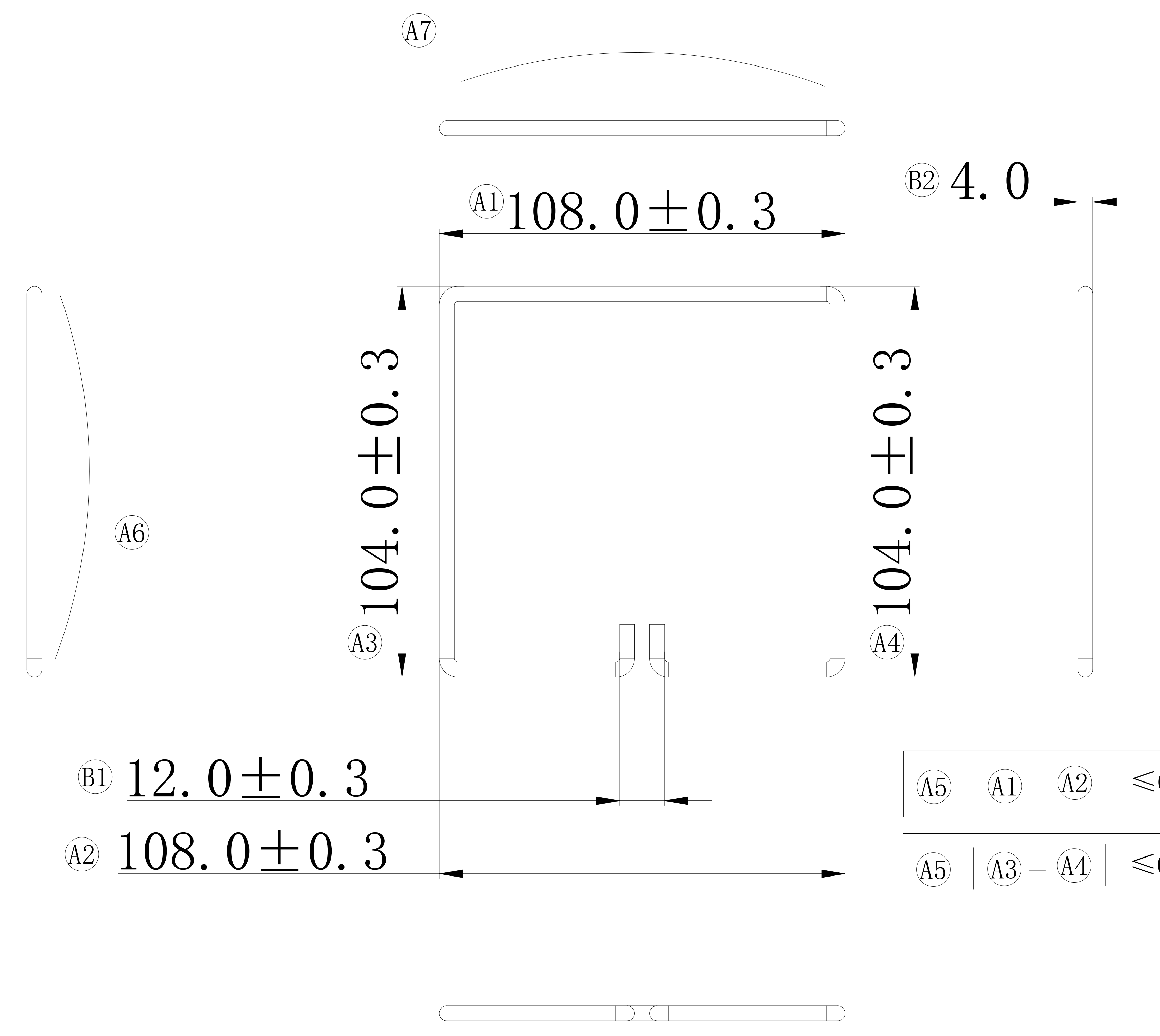
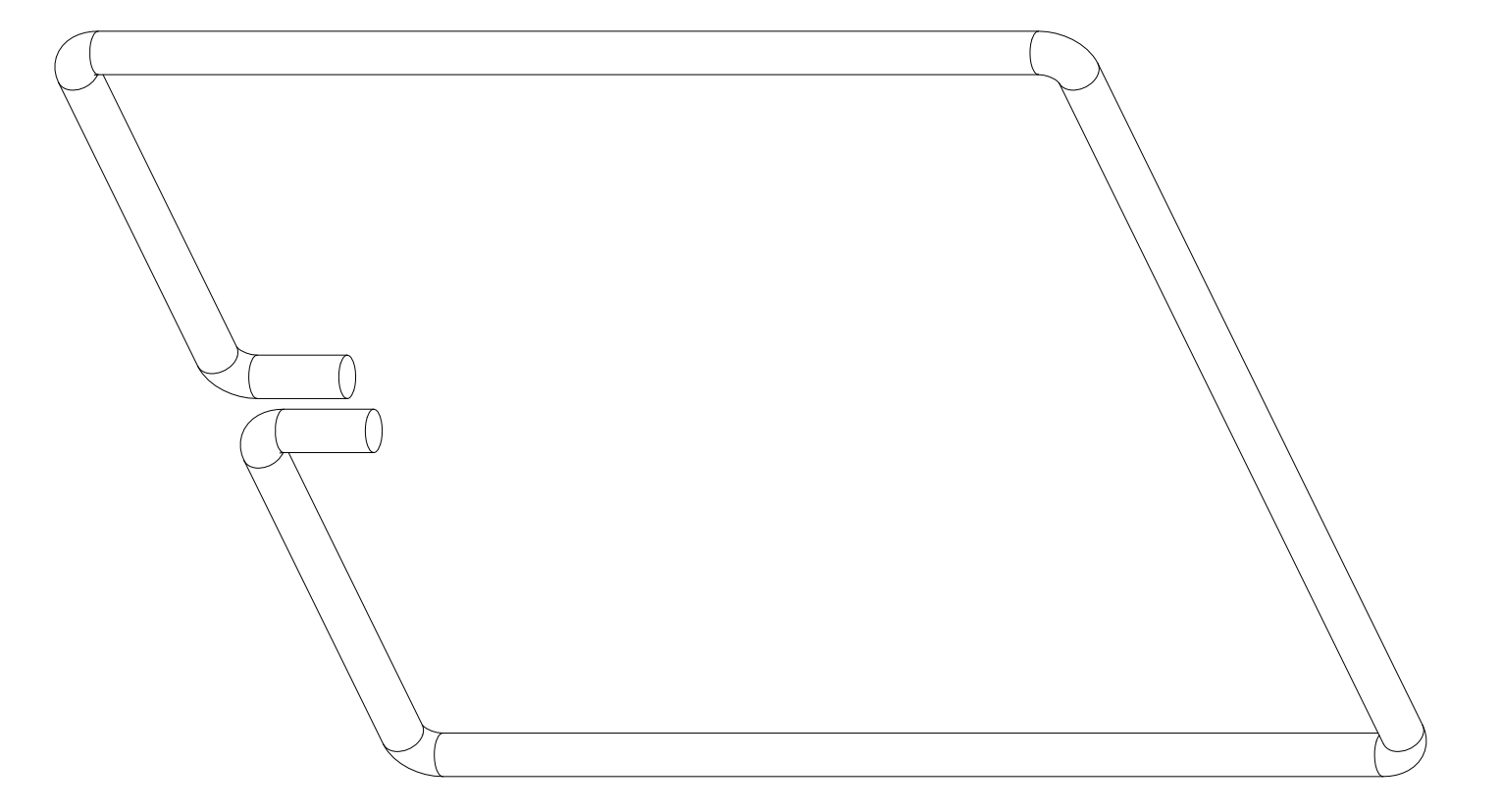

A5	A1 - A2	$\leq 0.3\text{mm}$
A5	A3 - A4	$\leq 0.3\text{mm}$

GENERAL LINEAR TOLERANCE				
STEP	1	2	3	SELECT LEVEL
0~25	0.05	0.1	0.2	2
25~100	0.1	0.15	0.2	
100~200	0.15	0.2	0.4	2
200~400	0.2	0.3	0.6	
400~700	0.3	0.4	1.0	2
700~1000	0.4	0.4	1.2	
1000~	0.5	0.6	1.5	2
ANGLE	$\pm 0.5^\circ$	$\pm 1.0^\circ$	$\pm 1.5^\circ$	

PART NUMBER		APPROVED		DATE	
68-WZSOA0-3					
PART DESCRIPTION		CHECKED		DATE	
MODEL NAME		DESIGNED		DATE	
				20240729	
UNIT	SCALE	PROJECT	SIZE	SHEET NUMBER	REVISION
MM	1:1	PROJECT	A3	1 OF 3	V1.0

16	17	18	19	20
VERSION	PROPOSER	REASON	MARK	REVISION
				DATE
				SIGN

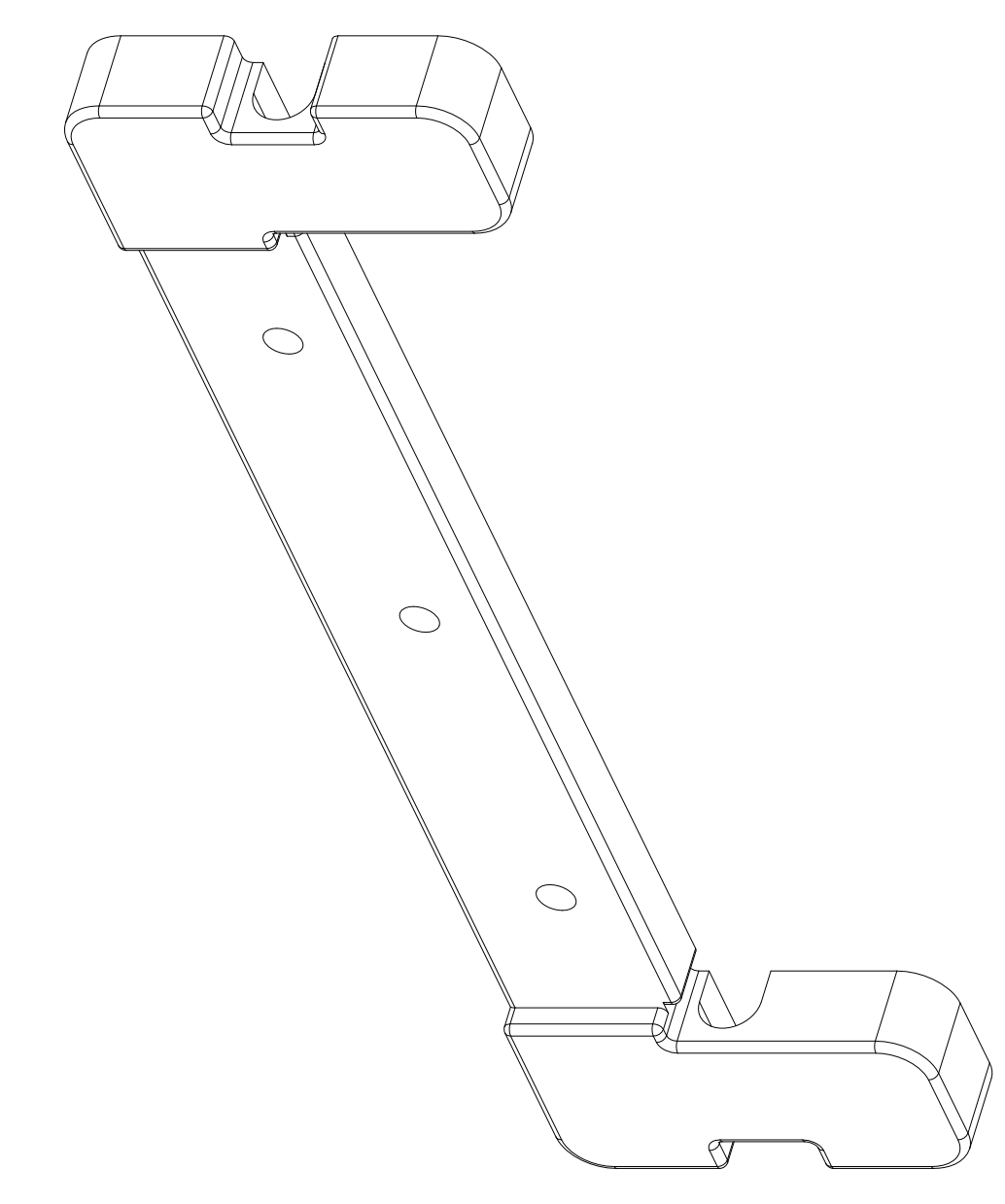
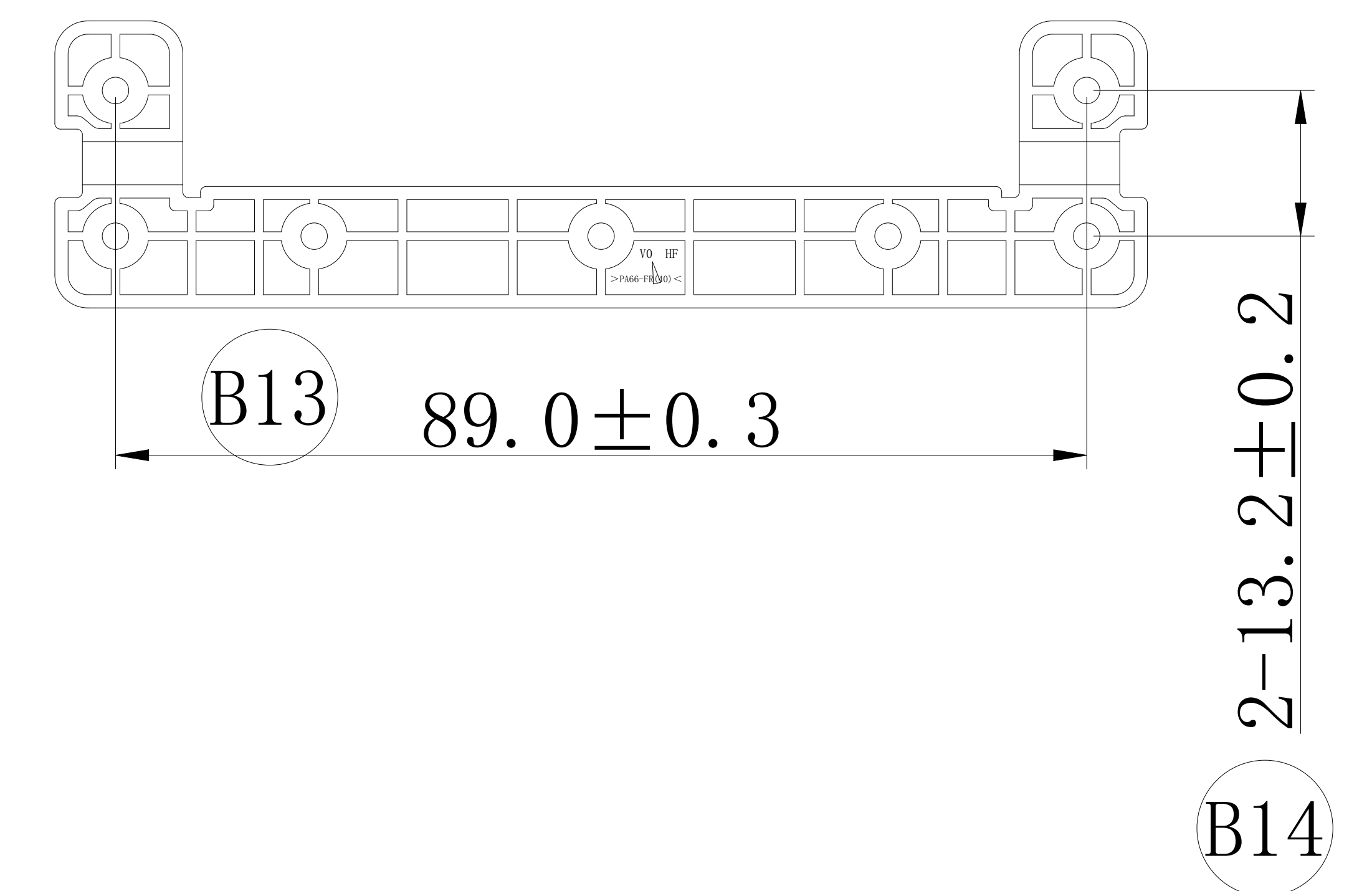
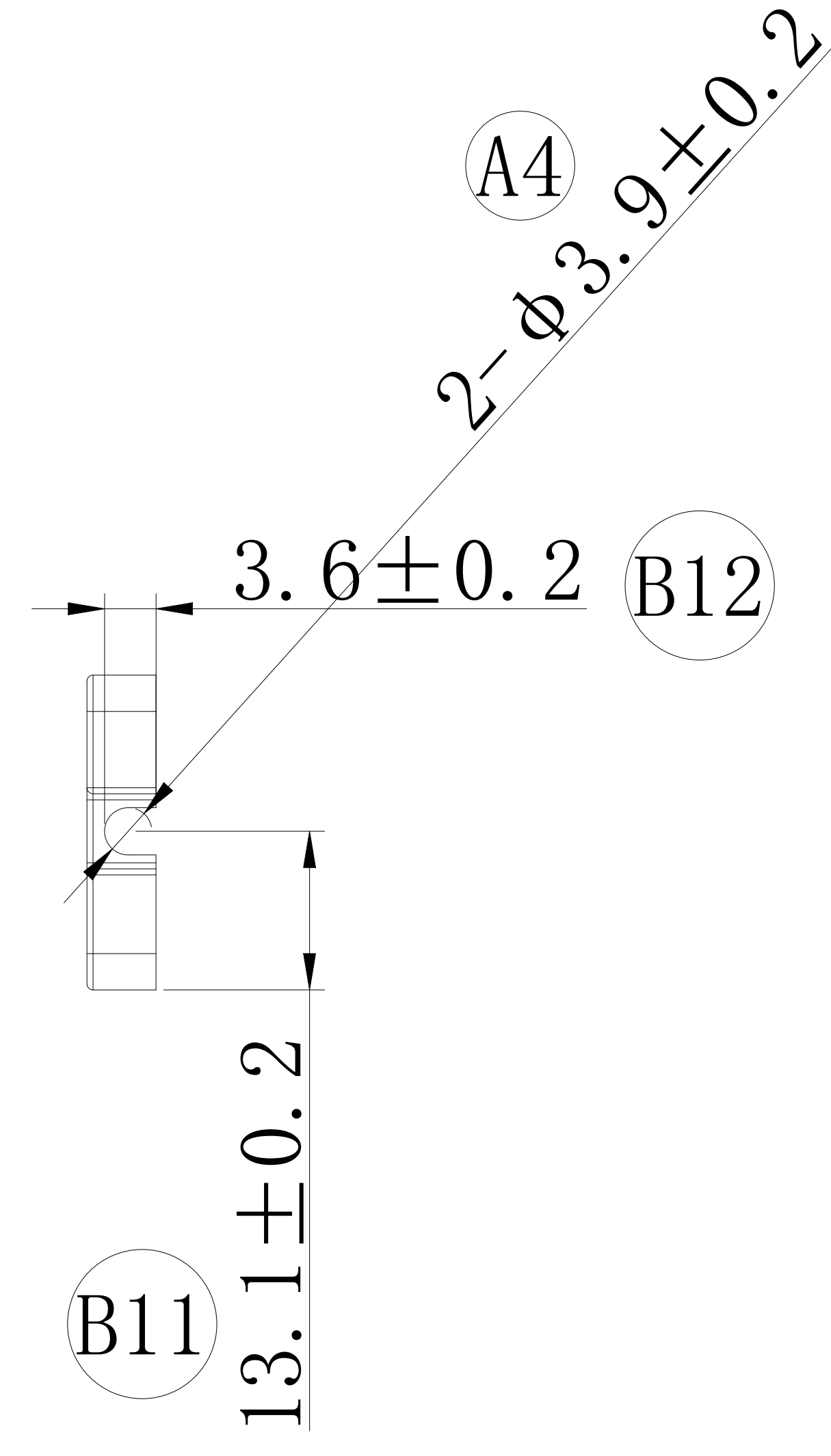
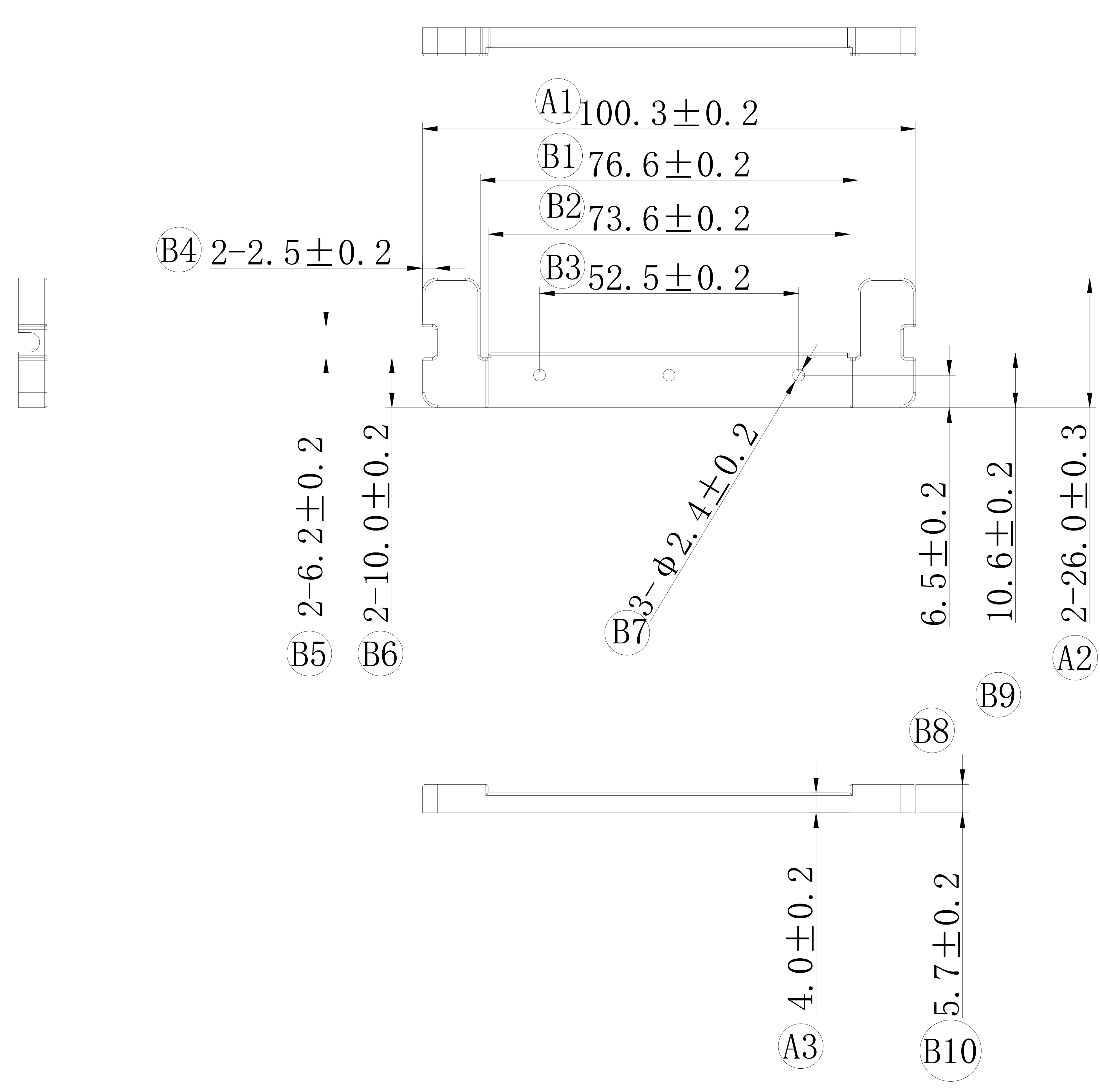

GENERAL LINEAR TOLERANCE				
STEP	1	2	3	SELECT LEVEL
0~25	0.05	0.1	0.2	2
25~100	0.1	0.15	0.2	
100~200	0.15	0.2	0.4	
200~400	0.2	0.3	0.6	2
400~700	0.3	0.4	1.0	
700~1000	0.4	0.4	1.2	
1000~	0.5	0.6	1.5	2
ANGLE	$\pm 0.5^\circ$	$\pm 1.0^\circ$	$\pm 1.5^\circ$	

PART NUMBER		APPROVED		DATE	
68-WZSOA0-4					
PART DESCRIPTION		CHECKED		DATE	
MODEL NAME		DESIGNED		DATE	
				20240729	
UNIT	SCALE	PROJECT	SIZE	SHEET NUMBER	REVISION
MM	1:1	PROJECT	A3	1 OF 3	V1.0

16	17	18	19	20
VERSION	PROPOSER	REASON	MARK	REVISION
				DATE
				SIGN

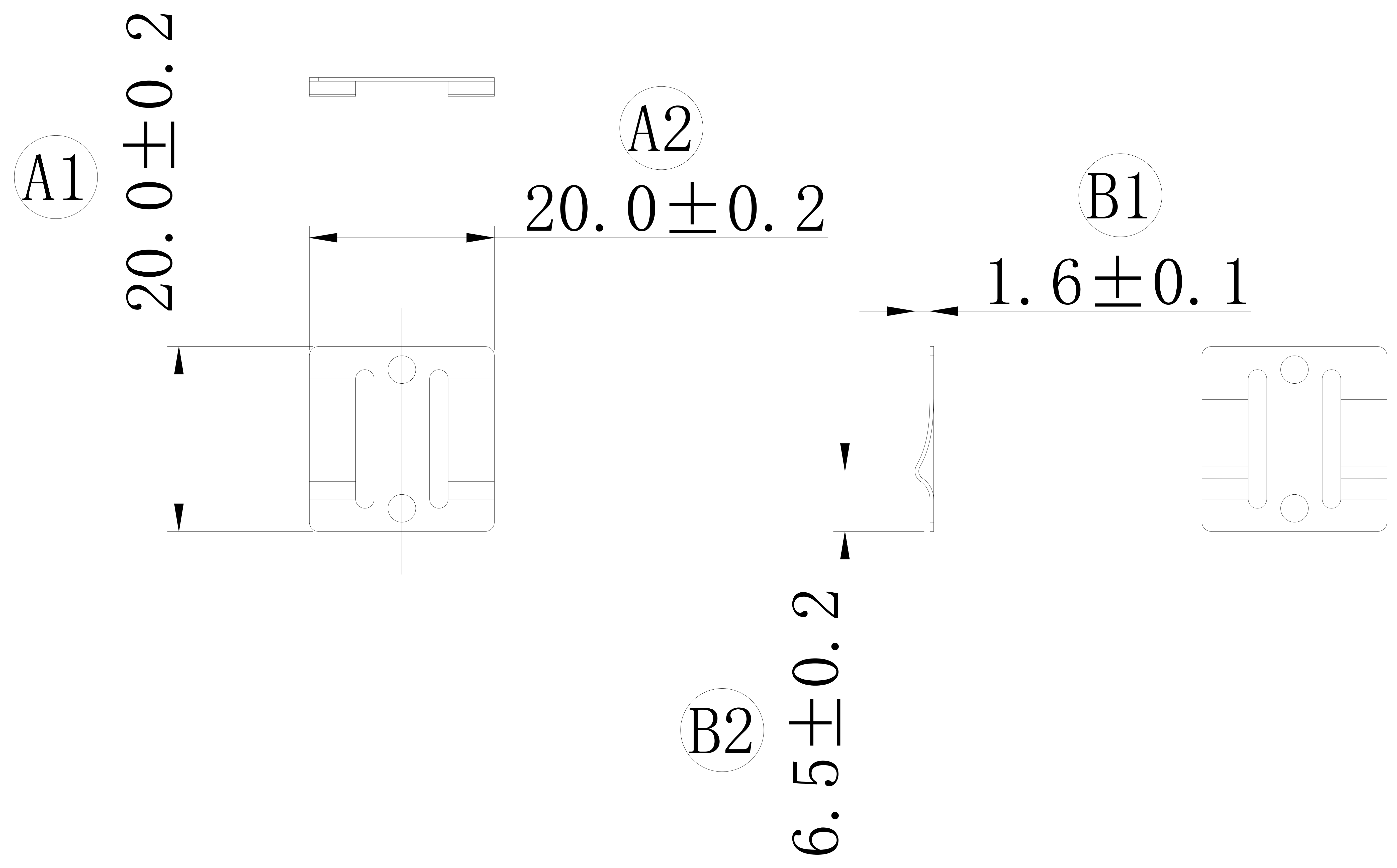
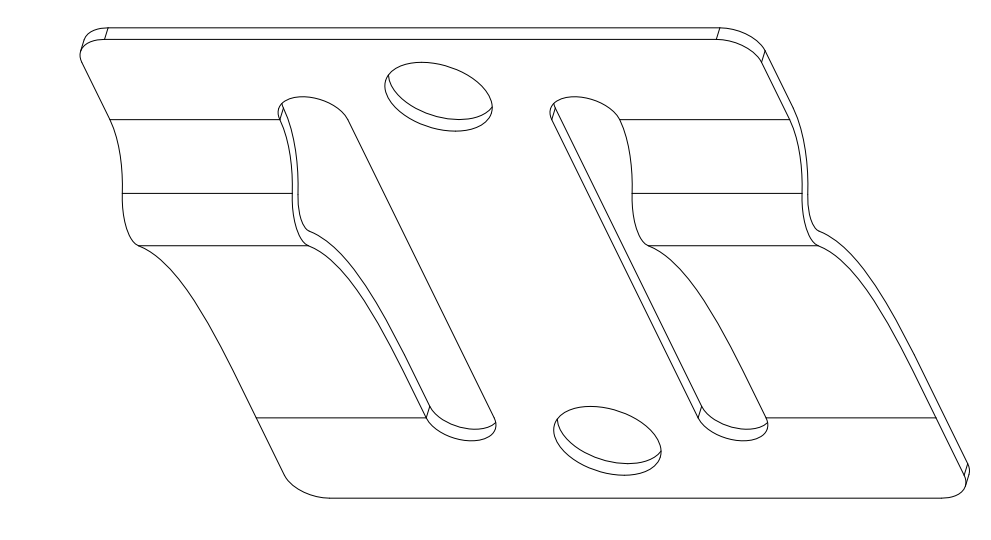

GENERAL LINEAR TOLERANCE				
STEP	1	2	3	SELECT LEVEL
0~25	0.05	0.1	0.2	2
25~100	0.1	0.15	0.2	
100~200	0.15	0.2	0.4	2
200~400	0.2	0.3	0.6	
400~700	0.3	0.4	1.0	2
700~1000	0.4	0.4	1.2	
1000~	0.5	0.6	1.5	2
ANGLE	$\pm 0.5^\circ$	$\pm 1.0^\circ$	$\pm 1.5^\circ$	

PART NUMBER		APPROVED		DATE	
68-WZSOA0-5					
PART DESCRIPTION		CHECKED		DATE	
MODEL NAME		DESIGNED		DATE	
				20240729	
UNIT	SCALE	PROJECT	SIZE	SHEET NUMBER	REVISION
MM	1:1	PROJECT	A3	1 OF 3	V1.0



16	17	18	19	20
VERSION	PROPOSER	REASON	MARK	REVISION

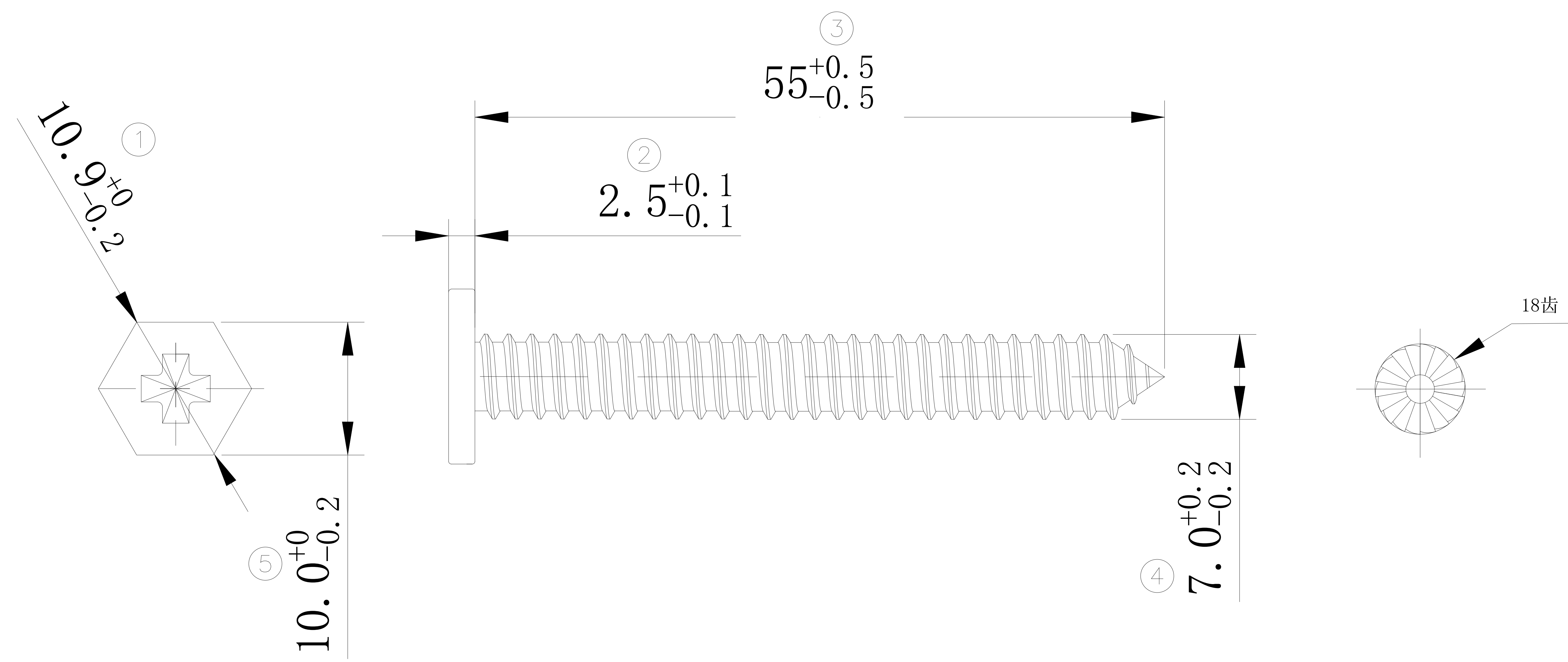

GENERAL LINEAR TOLERANCE				
STEP	1	2	3	SELECT LEVEL
0~25	0.05	0.1	0.2	2
25~100	0.1	0.15	0.2	
100~200	0.15	0.2	0.4	2
200~400	0.2	0.3	0.6	
400~700	0.3	0.4	1.0	2
700~1000	0.4	0.4	1.2	
1000~	0.5	0.6	1.5	2
ANGLE	±0.5°	±1.0°	±1.5°	

PART NUMBER		APPROVED		DATE	
68-WZS0A0-7					
PART DESCRIPTION		CHECKED		DATE	
MODEL NAME		DESIGNED		DATE	
				20240729	
UNIT	SCALE	PROJECT	SIZE	SHEET NUMBER	REVISION
MM	1:1	PROJECT	A3	1 OF 3	V1.0



16	17	18	19	20
VERSION	PROPOSER	REASON	MARK	REVISION

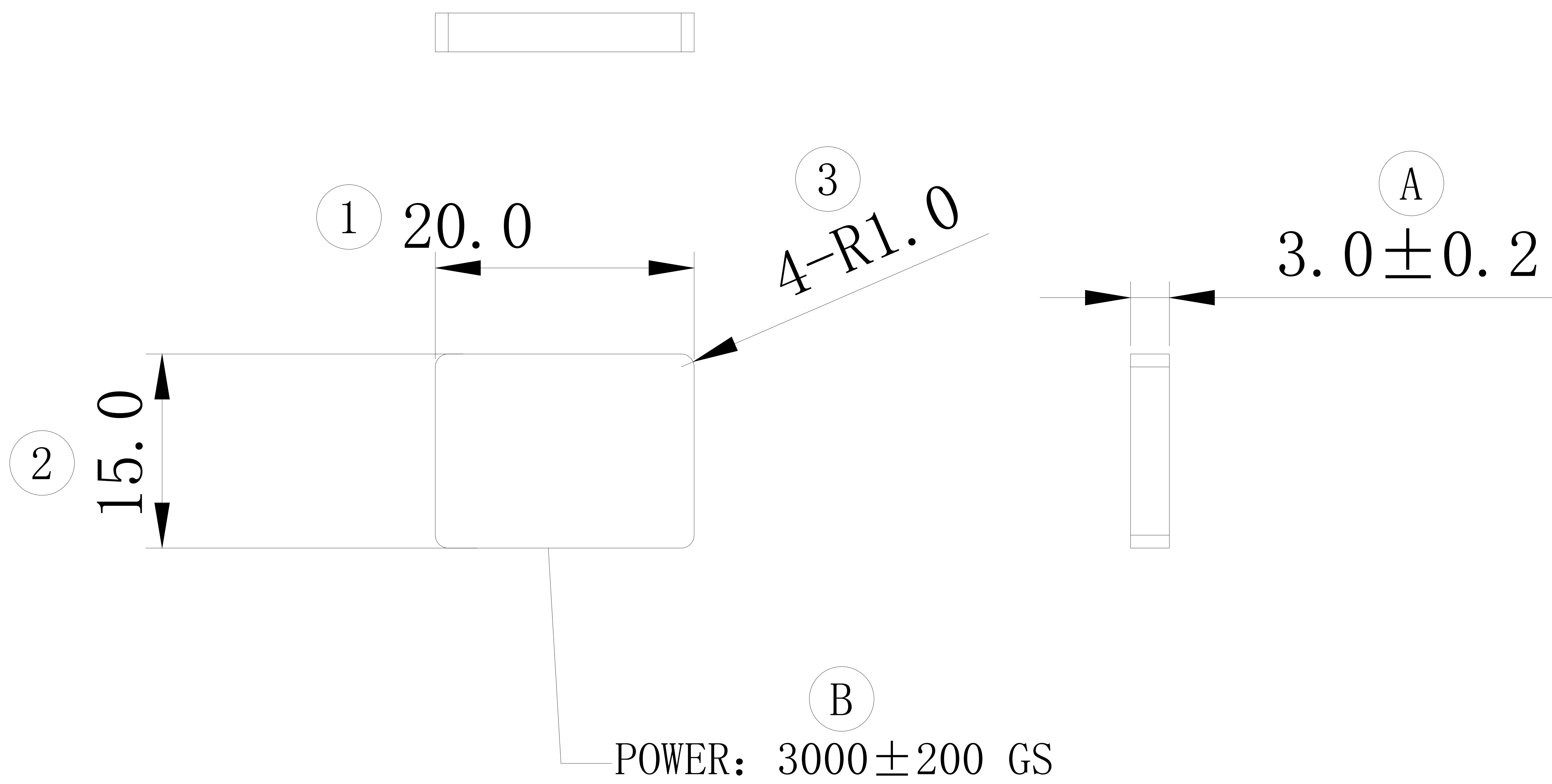

GENERAL LINEAR TOLERANCE				
STEP	1	2	3	SELECT LEVEL
0~25	0.05	0.1	0.2	2
25~100	0.1	0.15	0.2	
100~200	0.15	0.2	0.4	
200~400	0.2	0.3	0.6	
400~700	0.3	0.4	1.0	2
700~1000	0.4	0.4	1.2	
1000~	0.5	0.6	1.5	2
ANGLE	±0.5°	±1.0°	±1.5°	

PART NUMBER		APPROVED		DATE	
68-WZSOA0-8					
PART DESCRIPTION		CHECKED		DATE	
MODEL NAME		DESIGNED		DATE	
UNIT	SCALE	PROJECT		SIZE	SHEET NUMBER
MM	1:1	PROJECT		A3	1 OF 3
				20240729	REVISION
					V1.0

16	17	18	19	20
VERSION	PROPOSER	REASON	MARK	REVISION

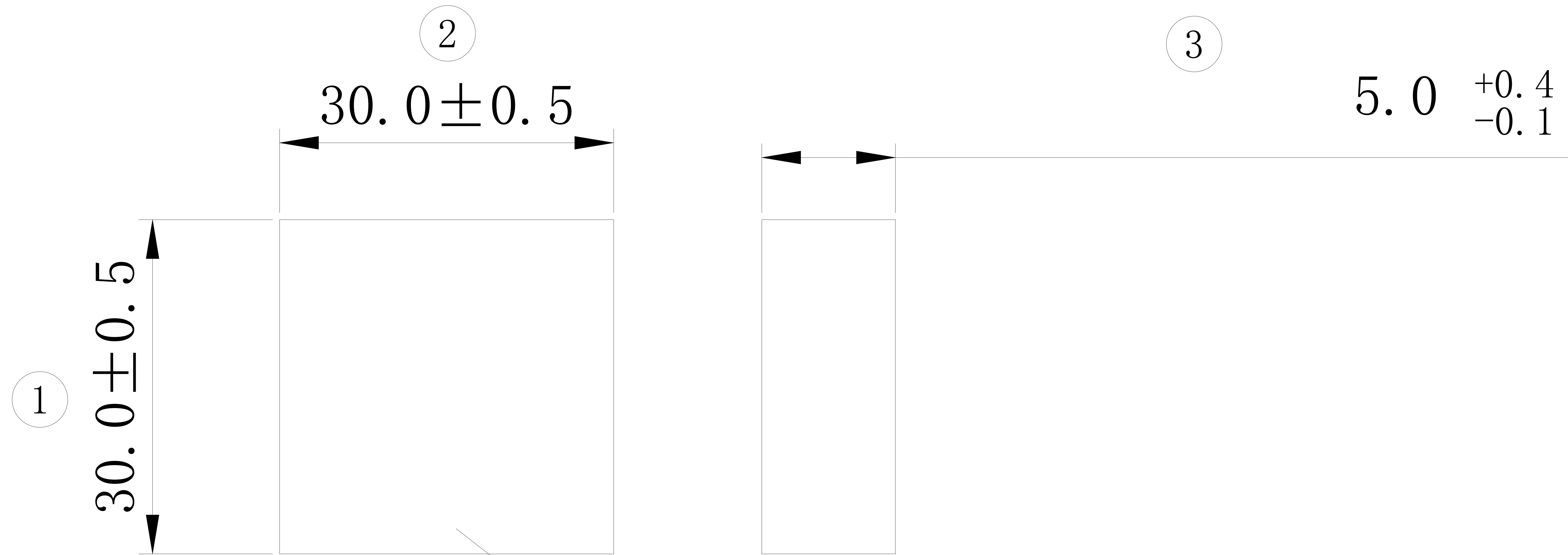

HM1215

GENERAL LINEAR TOLERANCE				
STEP	1	2	3	SELECT LEVEL
0°25	0.05	0.1	0.2	2
25°100	0.1	0.15	0.2	
100°200	0.15	0.2	0.4	2
200°400	0.2	0.3	0.6	
400°700	0.3	0.4	1.0	2
700°1000	0.4	0.4	1.2	
1000°	0.5	0.6	1.5	2
ANGLE	±0.5°	±1.0°	±1.5°	

PART NUMBER		APPROVED		DATE	
68-WZSOA0-9					
PART DESCRIPTION		CHECKED		DATE	
MODEL NAME		DESIGNED		DATE	
UNIT	SCALE	PROJECT	SIZE	SHEET NUMBER	REVISION
MM	1:1	PROJECT	A3	1 OF 3	V1.0

20240729

16	17	18	19	20
VERSION	PROPOSER	REASON	MARK	REVISION

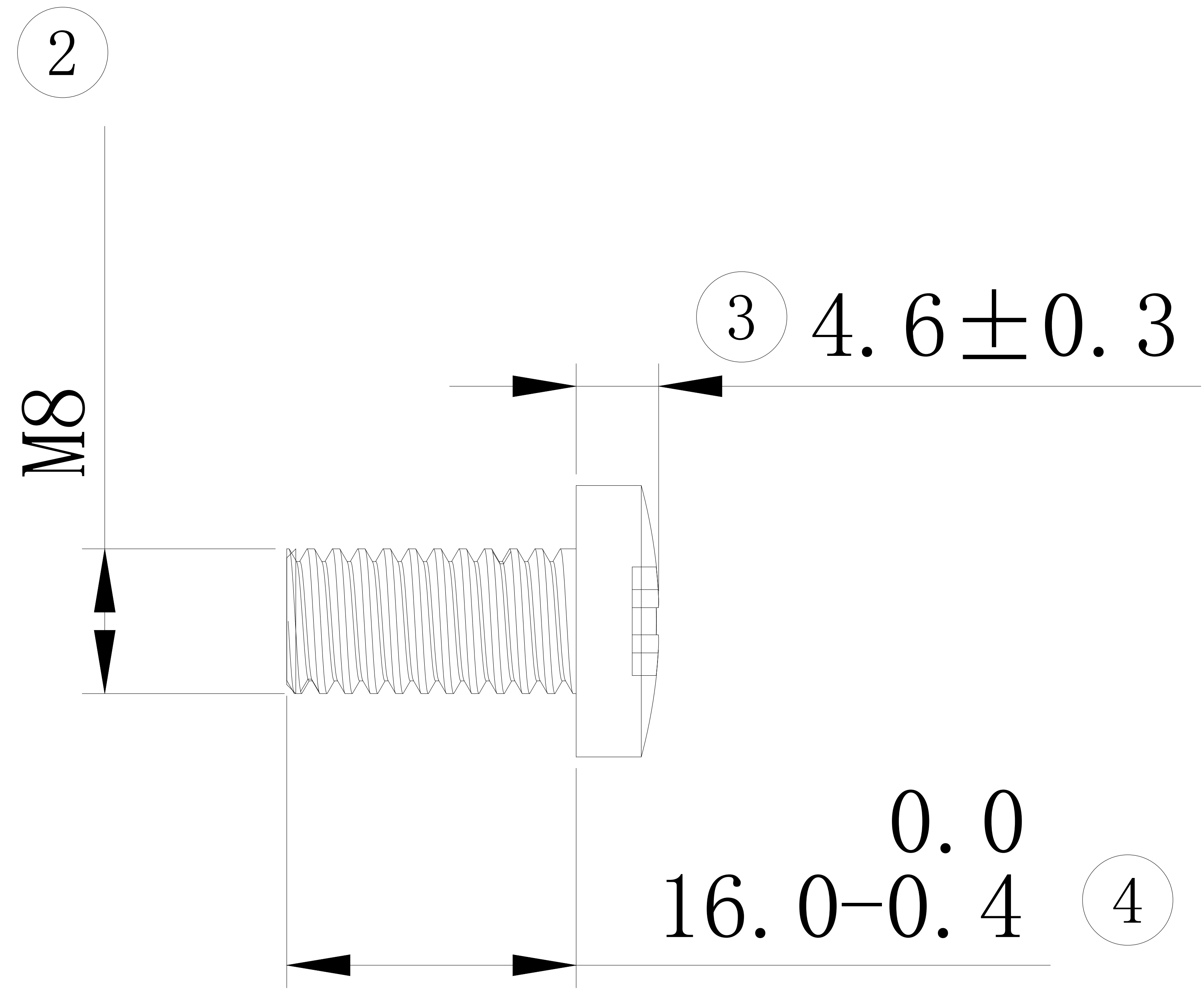
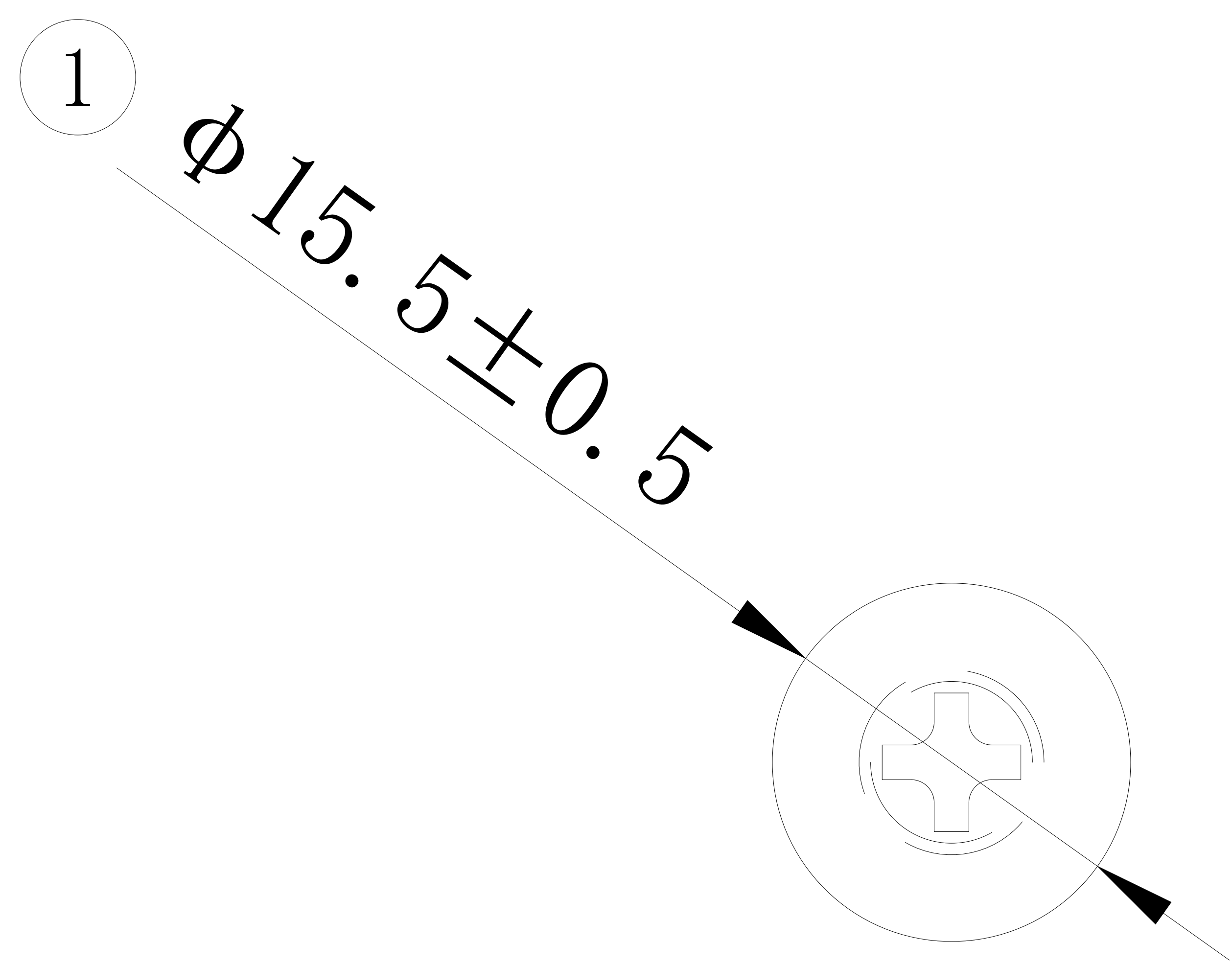

GENERAL LINEAR TOLERANCE				
STEP	1	2	3	SELECT LEVEL
0~25	0.05	0.1	0.2	2
25~100	0.1	0.15	0.2	
100~200	0.15	0.2	0.4	2
200~400	0.2	0.3	0.6	
400~700	0.3	0.4	1.0	2
700~1000	0.4	0.4	1.2	
1000~	0.5	0.6	1.5	2
ANGLE	±0.5°	±1.0°	±1.5°	

PART NUMBER		APPROVED	DATE
68-WZSOA0-10			
PART DESCRIPTION		CHECKED	DATE
MODEL NAME		DESIGNED	DATE
UNIT	SCALE	PROJECT	SIZE
MM	1:1		A3
			SHEET NUMBER
			1 OF 3
			REVISION
			V1.0
			20240729

16	17	18	19	20
VERSION	PROPOSER	REASON	MARK	REVISION

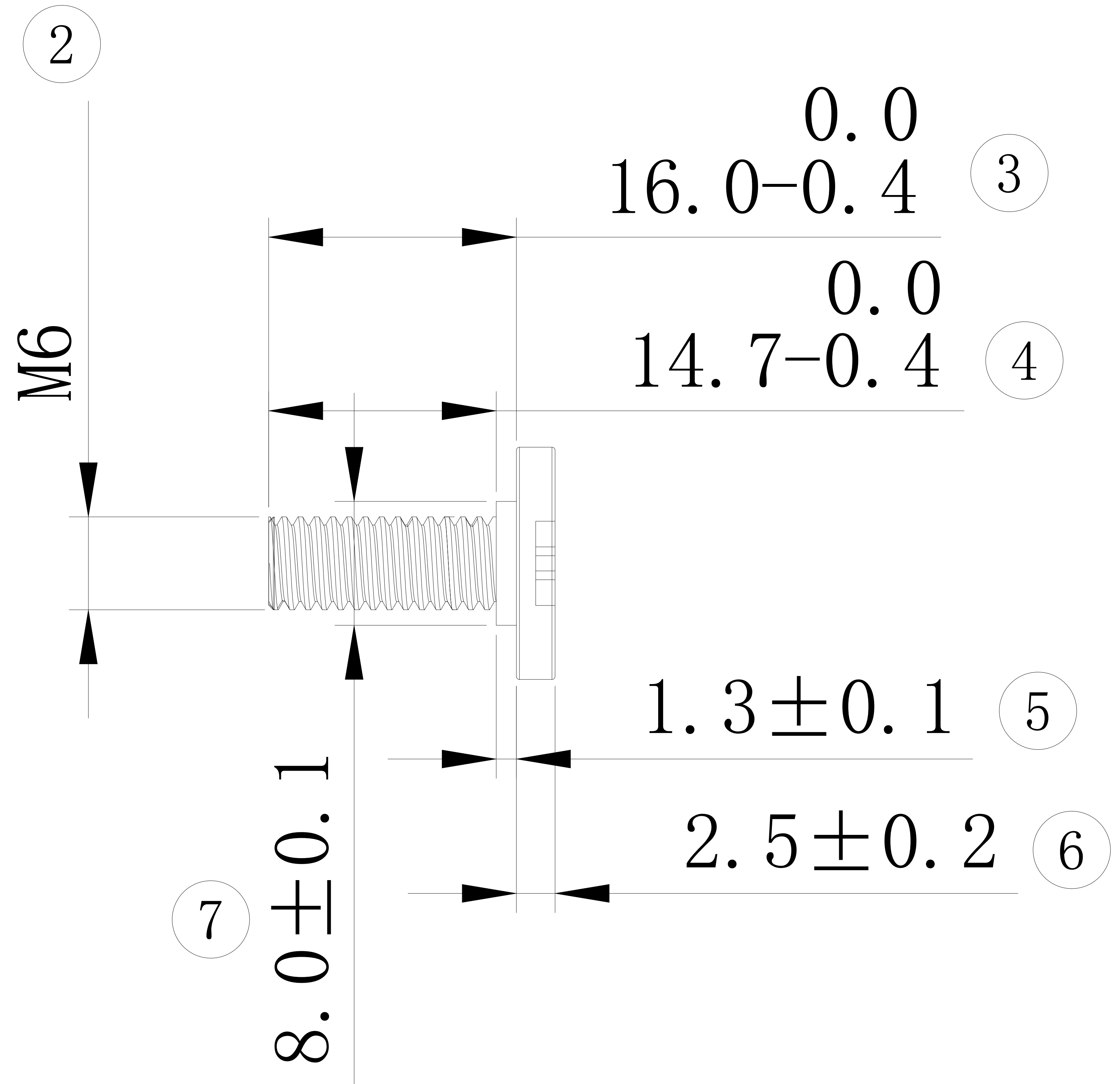
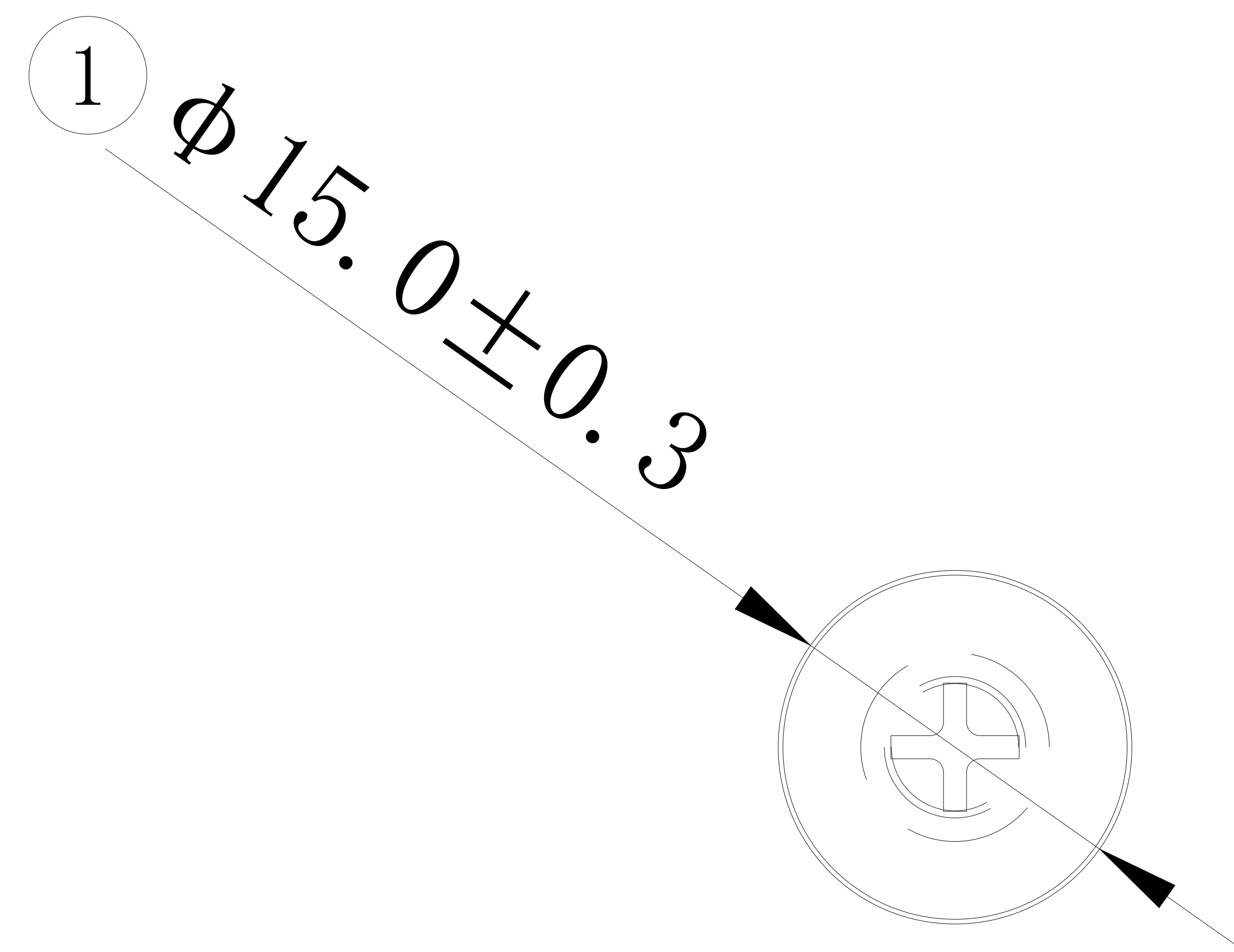

GENERAL LINEAR TOLERANCE				
STEP	1	2	3	SELECT LEVEL
0~25	0.05	0.1	0.2	2
25~100	0.1	0.15	0.2	
100~200	0.15	0.2	0.4	2
200~400	0.2	0.3	0.6	
400~700	0.3	0.4	1.0	2
700~1000	0.4	0.4	1.2	
1000~	0.5	0.6	1.5	2
ANGLE	±0.5°	±1.0°	±1.5°	

PART NUMBER		APPROVED		DATE	
68-WZSOA0-11					
PART DESCRIPTION		CHECKED		DATE	
MODEL NAME		DESIGNED		DATE	
				20240729	
UNIT	SCALE	PROJECT	SIZE	SHEET NUMBER	REVISION
MM	1:1	PROJECT	A3	1 OF 3	V1.0

16	17	18	19	20
VERSION	PROPOSER	REASON	MARK	REVISION

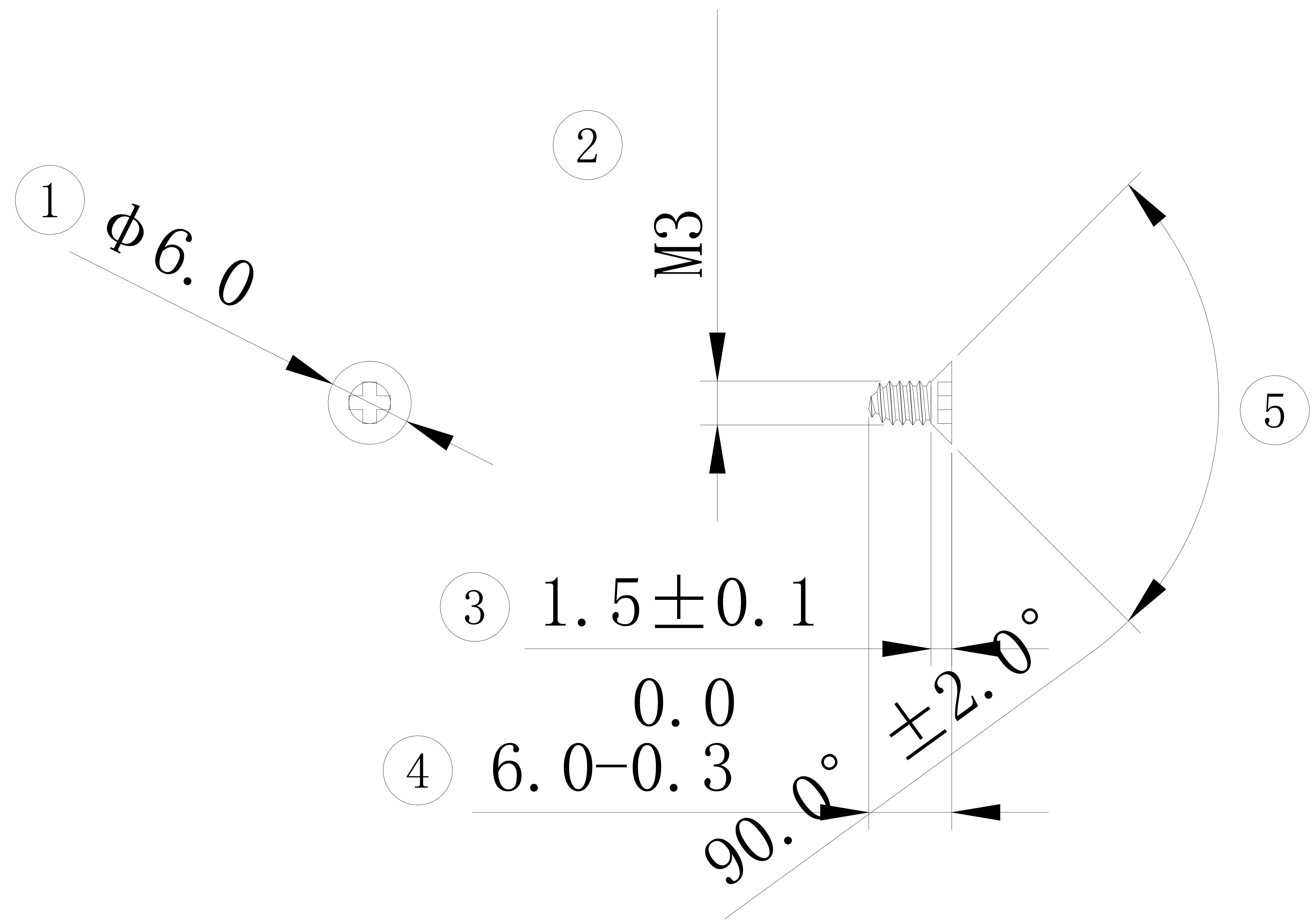

GENERAL LINEAR TOLERANCE				
STEP	1	2	3	SELECT LEVEL
0~25	0.05	0.1	0.2	2
25~100	0.1	0.15	0.2	
100~200	0.15	0.2	0.4	2
200~400	0.2	0.3	0.6	
400~700	0.3	0.4	1.0	2
700~1000	0.4	0.4	1.2	
1000~	0.5	0.6	1.5	2
ANGLE	$\pm 0.5^\circ$	$\pm 1.0^\circ$	$\pm 1.5^\circ$	

PART NUMBER		APPROVED		DATE	
68-WZSOA0-12					
PART DESCRIPTION		CHECKED		DATE	
MODEL NAME		DESIGNED		DATE	
				20240729	
UNIT	SCALE	PROJECT	SIZE	SHEET NUMBER	REVISION
MM	1:1	PROJECT	A3	1 OF 3	V1.0