

DV One+ 163" Mobile Cart Installation Manual

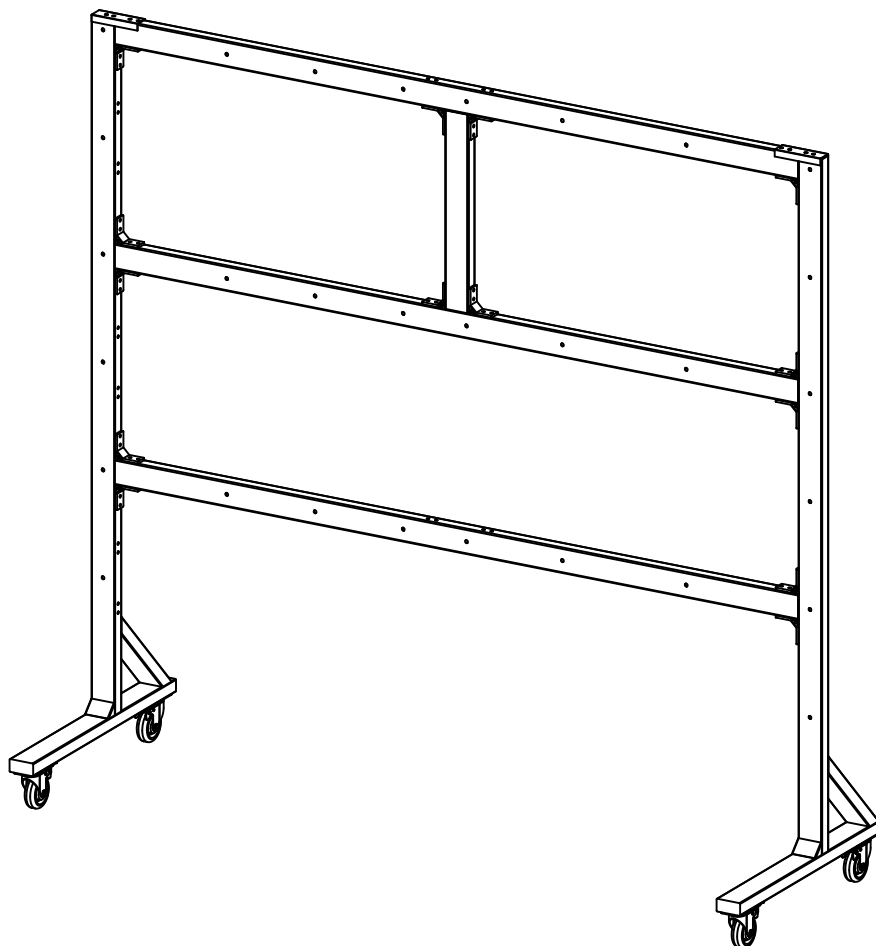

Model: DV One+ 163" Mobile Cart

- To use the product safely and correctly, please read this manual carefully before installation.
- This product is suitable for the DV One+ 163" display.

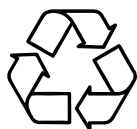

● Main Parts:

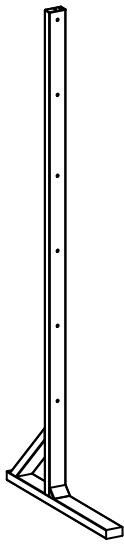

A-left column 1pc

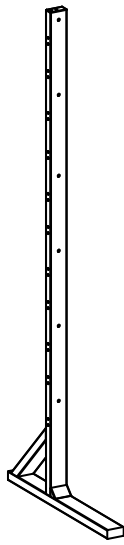

1pc

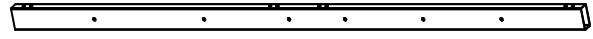

C-Crossbeam 3pcs

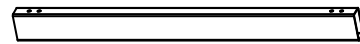

D - Middle vertical bar 1pc

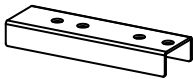

E-beam connecting piece 2pcs





F-Aluminum corner code 16pcs





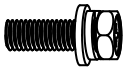
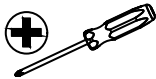

G-4 inch wheels 4pcs

● Bracket assembly screw package:

		
a-M8*20 cross hexagonal screws 84pcs	Cross wrench (self provided)	Adjustable wrench (Self provided)

● LED all-in-one machine screw package:

			
φ18*8.5*1.5 iron gaskets 16pcs	φ 8.5*2.1 spring washers 16pcs	φM8*65 external hexagonal cross screw 16pcs	M8*8 anti slip nuts 16pcs

Step 1 : Adjust the wheels to the braking position and use screw (a) to lock the wheels onto the left and right pillars. (As shown in Figure 1).

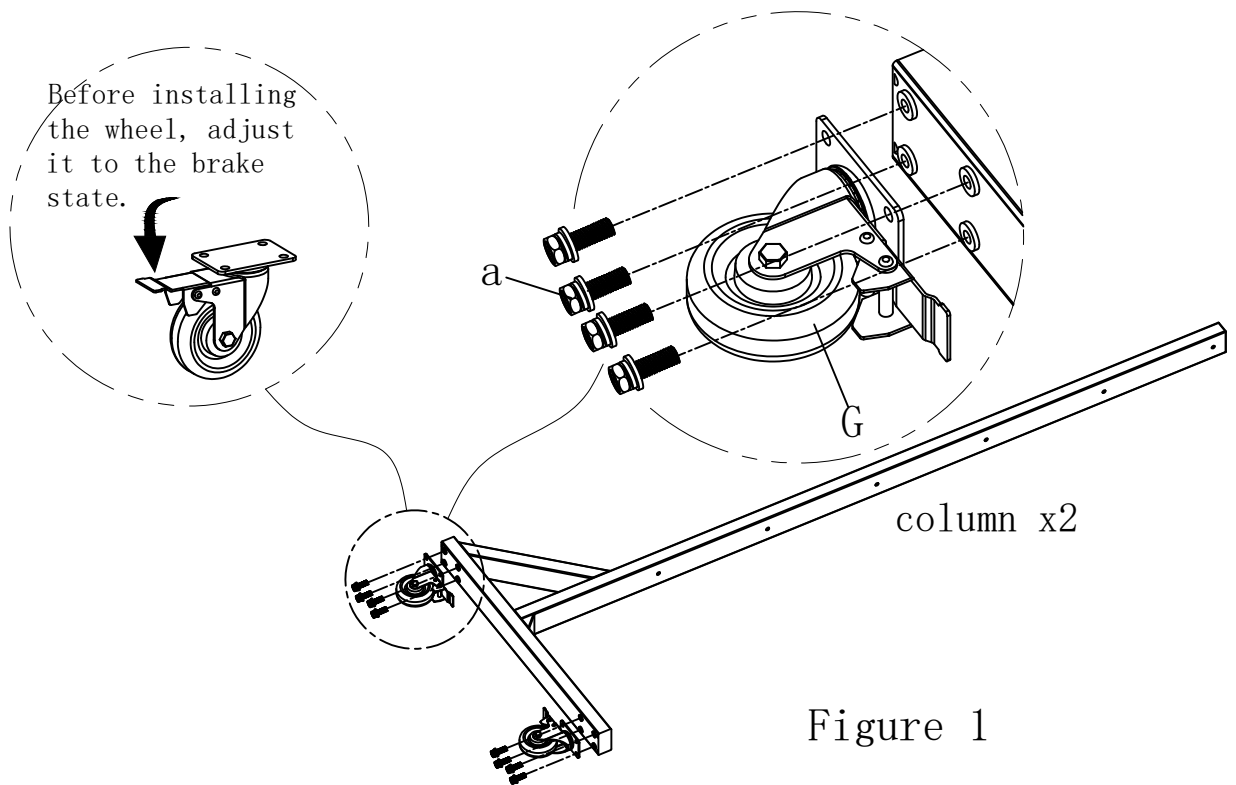

Figure 1

Step 2 : Select the appropriate installation method based on the predetermined height of the monitor;

2.1 The highest position for installing the crossbeam:

2.1.1 Take out the aluminum corner code and the connecting piece of the crossbeam, install it in combination with the three crossbeams as shown in the diagram, and lock it with screws on both sides for backup. (Figure 2)

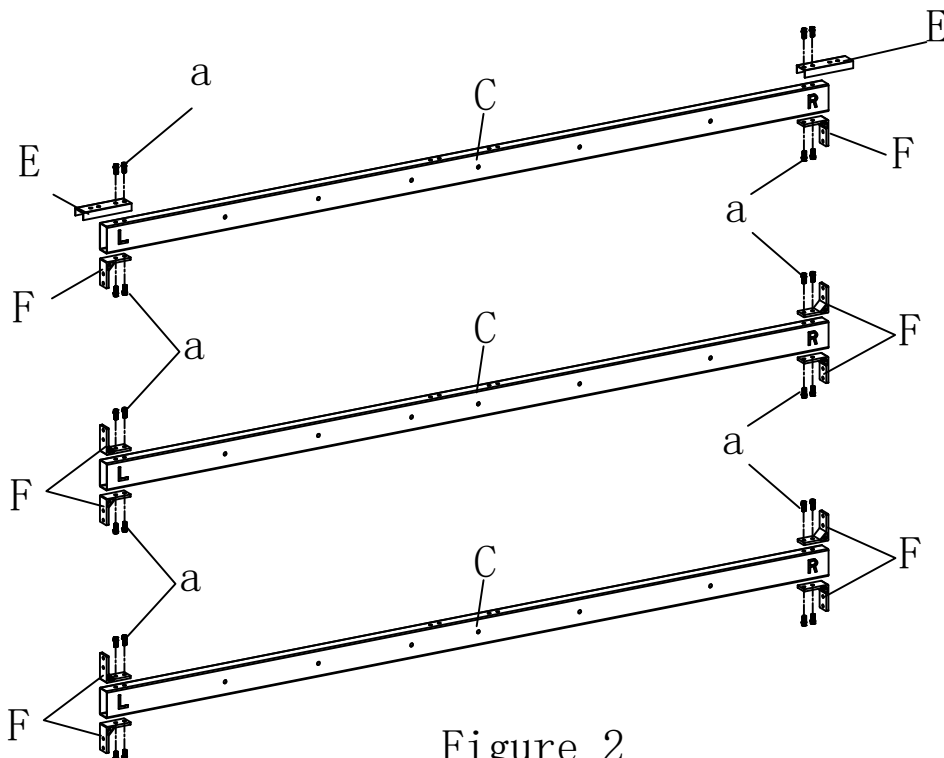

Figure 2

2.1.2 Assemble the pre assembled crossbeam and left and right columns according to the diagram, paying attention to the direction of the upper and lower crossbeams, and use screws (a) to lock and fix them. (as shown in Figure 3).

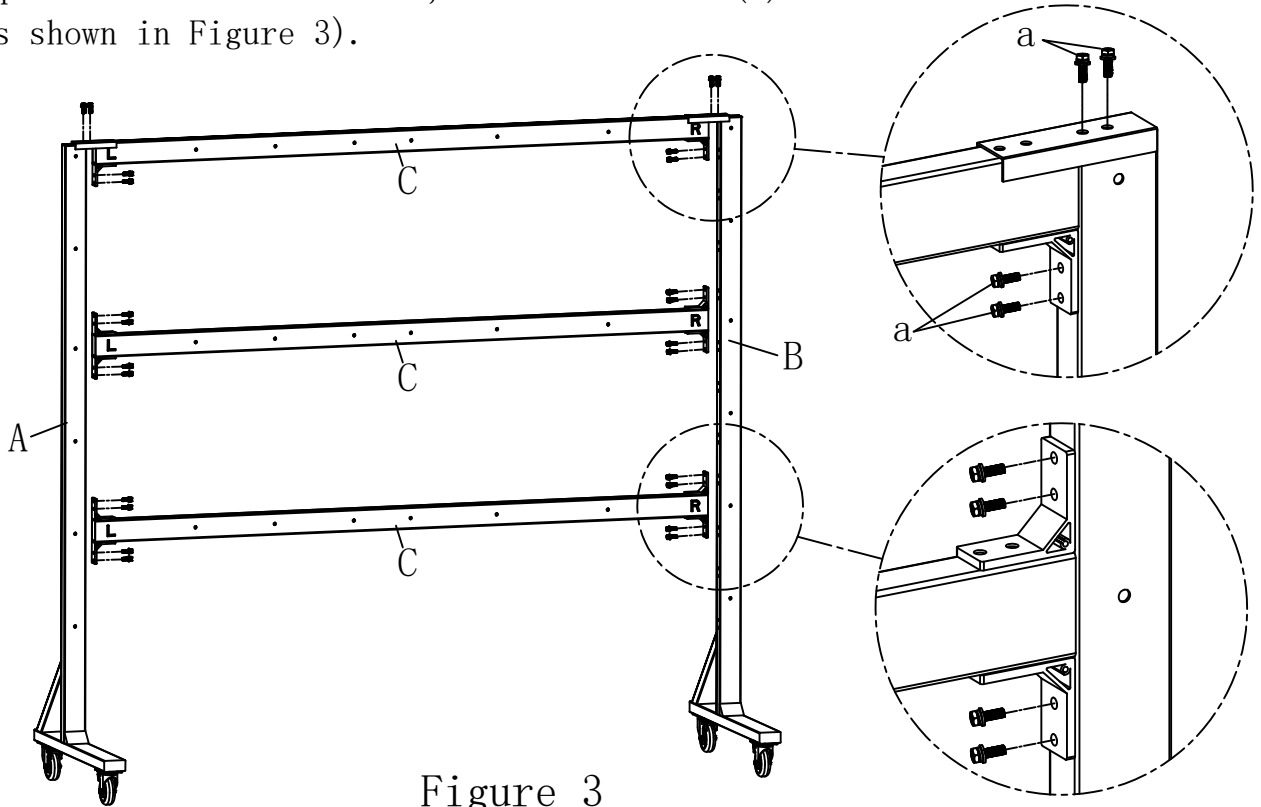

Figure 3

2.2 Installation of crossbeam at non highest position:

2.2.1 Take out the aluminum corner code, install it in combination with three crossbeams as shown in the diagram, and lock it with screws (a) on both sides for later use. (Figure 4)

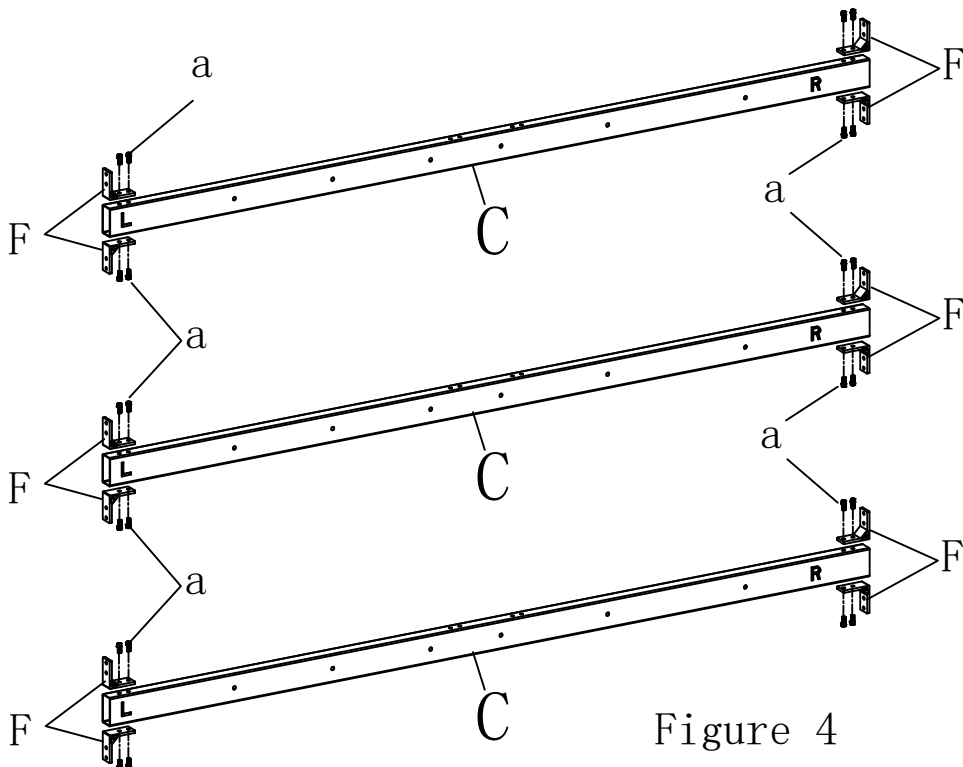

Figure 4

2.2.2 Assemble the pre assembled crossbeam with the left and right columns, and lock them with screws (a).
(As shown in Figure 5)

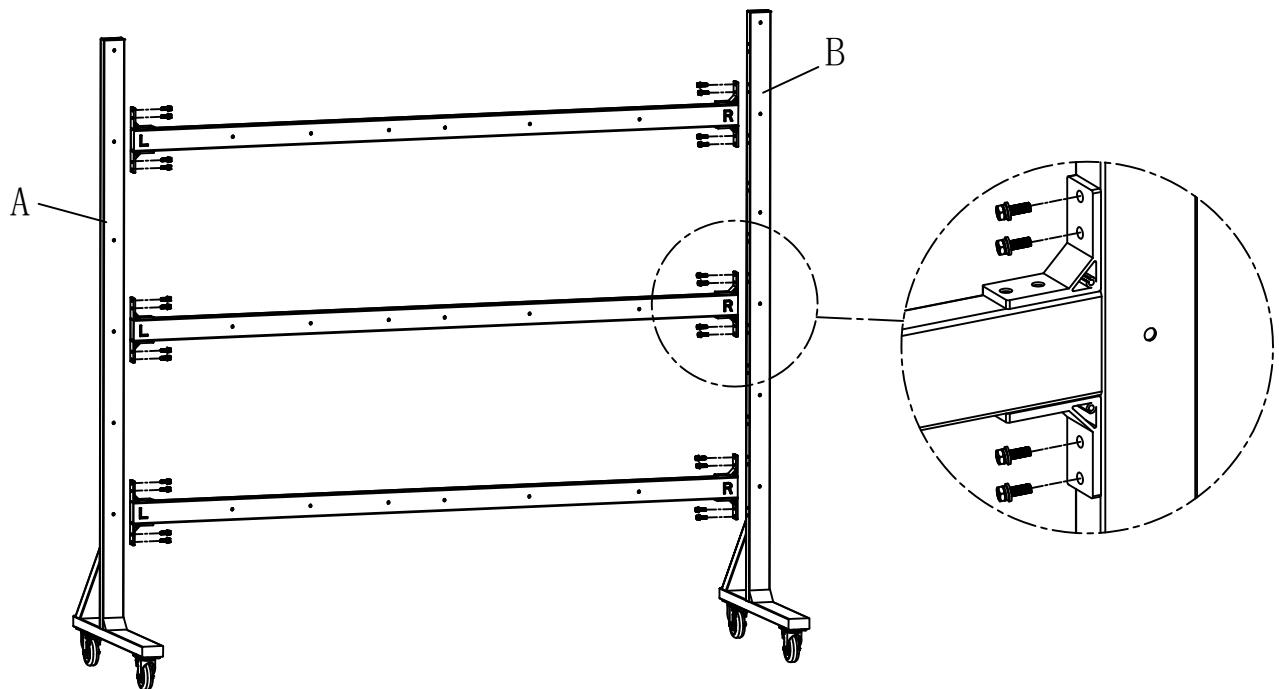
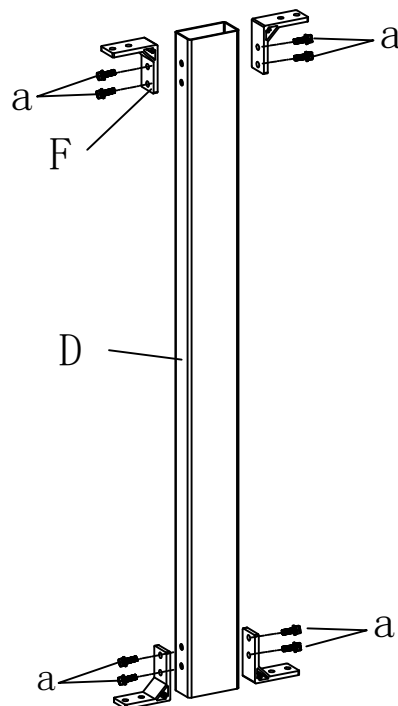
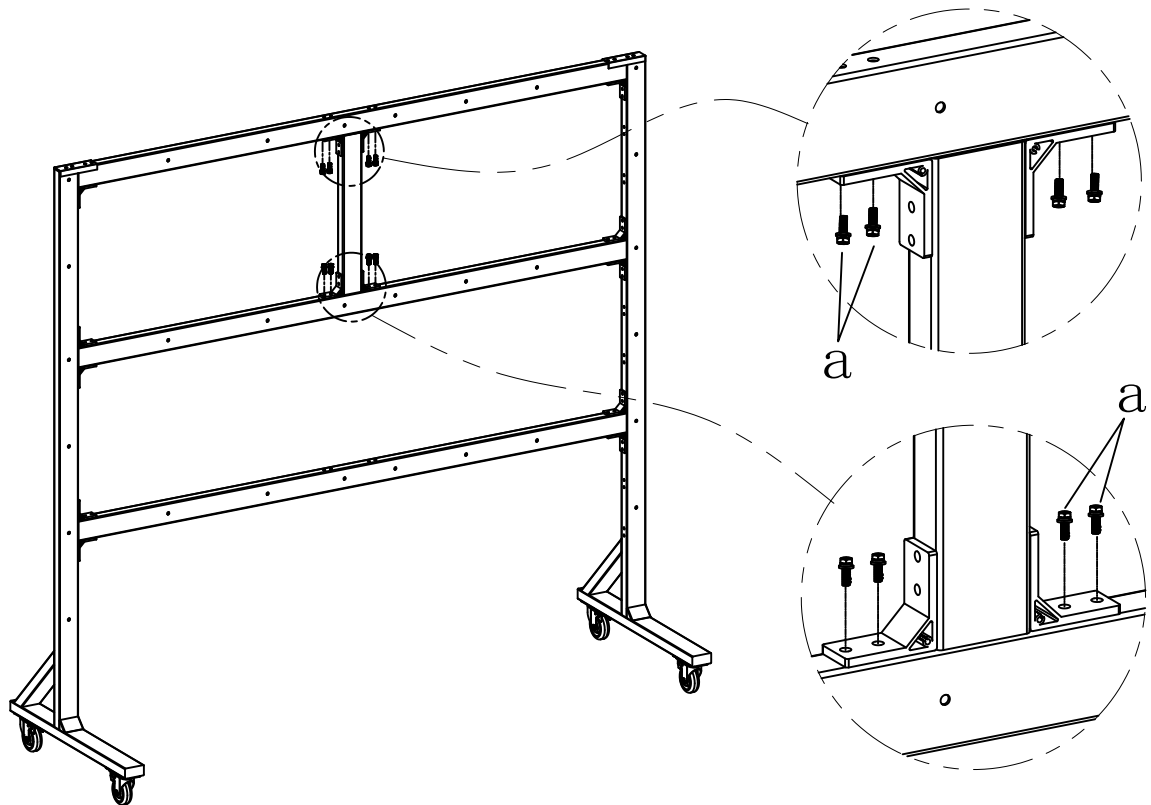

Figure 5

Step 3 : Install aluminum corner brackets at the bottom and top of the middle vertical bar, and lock them with screws (a) for backup.



Step 4: Then assemble the pre assembled middle vertical bar with the crossbeam and use screws (a) Lock it tightly.



Step 5: Install the crossbeam fixing plate onto the crossbeam using fasteners as shown. After installation, check all screws to prevent them from loosening.

The mobile cart has been assembled, please follow the assembly instructions of the LED all-in-one machine for assembly.

