



# Pro Series User Manual

## Introduction

This manual may contain technical inaccuracies, operational inconsistencies, or typographical errors. We will update the content as product features are enhanced, and will periodically improve or revise the products and procedures described herein. Updates will be included in future versions of this manual without prior notice.

## Environmental Declaration

Comply with local regulations regarding equipment packaging materials, depleted batteries, and disposal of used equipment, and support recycling initiatives.

## About This Manual

This document is used to guide users. The screenshots and diagrams in this document are for explanation only. The actual situation may vary.

## Agreement

Pattern	Agreement
	Note: Add necessary information to the description of the operation content

Symbol	Agreement
黑体	Interface menu, such as click Zoom

## Precautions for Installation and Use

- Do not install devices in flammable and explosive environments.
- The temperature and humidity at the installation site must be within the normal operating range.
- Keep the device near vents to prevent heat accumulation.
- Ensure adequate clearance around the device to facilitate proper heat dissipation
- Do not remove device parts or connect cables while the power is on
- Implement Electrostatic Discharge (ESD) protection measures during installation and maintenance.  
Before handling the product, wear an ESD wrist strap or grounded ESD gloves. All tools must be strictly grounded during assembly.
- The shell, cabinet, and screen of the switching power supply must be strictly grounded with a grounding resistance of no more than 10 ohms. Perform spot checks every six months.
- Do not knock, scratch, bump, or scratch the display surface with hard objects.
- Do not flood or soak the device.
- Do not turn the air outlet of the air conditioner directly against the display or make the temperature difference between the inside and outside of the display too large.
- Do not place or use the display in an environment where volatile, corrosive, or combustible chemicals are present.
- When cleaning the surface of the LED module, do not use unknown chemical liquids to avoid damage or corrosion of the LED.
- When cleaning the LED tube, gently wipe it with a clean soft rag dipped in alcohol, and wait until dry before use.
- When cleaning the kit, wipe the kit gently with clean soft cloth dipped in water. Do not leave any trace of water after wiping, and dry the kit before using.
- It is strictly prohibited to install and debug the large screen during the interior decoration.
- If any abnormal situation occurs on the display, such as odor, smoke, leakage, abnormal temperature, wading in the screen, etc., please cut off the power supply immediately, and then contact our technical personnel.
- Under normal circumstances, ensure that the display is on at least twice a week and the startup time is not less than 2 hours; It should be lit for no less than 2 hours a day during the return of tide.
- In order to ensure the display effect of the LED, it is necessary to regularly clean the dust with a soft anti-static brush.
- When servicing LED modules, it is recommended to use a thermostatic electric soldering iron, the temperature of the electric soldering iron is adjusted according to the composition of the tin wire.
- When repairing LED welding, the electric soldering iron temperature is generally set at about 315°C, the welding time is not more than 5s (preferably 3s), and the welding number is not more than three times.
- When repairing CMOS devices, the soldering iron temperature must be kept below 315°C, the welding time should not exceed 3s, and the welding times should not exceed three times.

- To ensure LED stability and service life, the module working surface temperature should not exceed 60°C, storage temperature should not exceed 60°C, otherwise necessary cooling measures must be taken.
- Use only the dedicated LED display switching power supply provided. The module adopts DC 4.6 input. Do not directly connect to 220V, otherwise the whole module will be burned.
- When installing the LED module, ensure that the power port is correctly connected, and the positive and negative terminals must correspond to each other; If the positive and negative terminals are reversed, power off in time to avoid damage to components.
- The module's operating voltage must not exceed 5.5V (maximum allowable).
- Avoid dropping, pushing, squeezing, or applying pressure to the module during use or transportation.

### Special statement

- The figures in this document are for reference only. The actual product shall prevail.
- We do our best to ensure that the information in this manual is correct. Information is subject to change without prior notice due to upgrades or other reasons.
- This manual can be used as a guide for the use of multiple models of products. However, the usage information of each product is not listed. Please check it according to the actual product.
- Access to the Internet is at your own risk, including but not limited to the product may be subjected to network attacks, hacker attacks, virus infection, etc. The Company will not be responsible for the resulting product abnormal work, information leakage and other problems, the company will provide you with product related technical support in a timely manner.

## Contents

<b>Chapter 1: Product Overview.....</b>	<b>7</b>
1.1 Features.....	7
1.2 Cabinet Appearance.....	8
1.3 Detailed Product Drawing.....	9
1.4 Internal Components of the cabinet.....	10
<b>Chapter 2: Installation and Wiring.....</b>	<b>11</b>
2.1 Out-of-cabinet Inspection.....	11
2.2 Common tools.....	12
2.3 Cabinet layout.....	13
2.4 Ground Installation Process.....	14-17
2.5 Back frame structure.....	18
2.6 Back Frame Installation.....	19-21
2.7 Signal Cable Connection.....	22
2.8 Power Cable Connection.....	22
2.9 Module Layout.....	23
2.10 Smart Control Distribution cabinet.....	24-25
2.11 Load Calculation.....	26
<b>Chapter 3: System Solution Overview.....</b>	<b>27</b>
3.1 Scope of Application.....	27
3.2 Specifications.....	28-29
<b>Chapter 4: LED Display Control Settings.....</b>	<b>30</b>
4.1 Power-on Testing.....	30
4.2 Preparation for Debugging.....	30
4.2.1 Starting the System.....	30
4.2.2 Installing the Software.....	30

## Contents

4.3 Display Configuration.....31-34

4.4 Brightness Adjustment.....34-35

4.5 Firmware Program Update.....36-38

4.6 Send calibration data to the receiver card.....39-40

4.7 Image Booster Engine.....41

4.8 Screen Play.....42-43

**Chapter 5: Hardware Troubleshooting Analysis.....44**

5.1. Module Failure.....44

5.2. Power Failure.....45

5.3. Data Transmission Faults.....46

5.4 Regular Maintenance and Precautions.....47

# Chapter 1: Product Overview

The Series offers ultra-high ink color consistency with a display that delivers mirror-black depth and bright visuals. Utilizing advanced flip-flop co-patterned Micro LED chips, it achieves energy savings of over 50%, with minimal temperature increase, ensuring high stability and reliability. The product is designed for exceptional durability, offering high resistance to pressure and impact, as well as being waterproof and dustproof. Its modular design allows for infinite splicing combinations with no visible seams, delivering an immersive and seamless visual experience. Additionally, the Series supports pre-maintenance, hot-swapping, and hassle-free operation for worry-free usage.

## 1.1 Features

### **(1) Low Power Consumption:**

Designed with a common cathode circuit, it offers energy efficiency, low power consumption, high refresh rates, HDR support, and 16-bit grayscale at low brightness levels.

### **(2) High Protection:**

Full-flip COB packaging technology offers robust protection, reliability, and environmental adaptability.

### **(3) High Precision:**

Die-cast aluminum cabinets with CNC finishing offer precise assembly with no visible seams.

### **(4) High Compatibility:**

Supports various panel pitches and sizes, with SMD, COB, IMD, and MIP packaging technologies, allowing for easy product updates and enhanced value.

# 1.2 Cabinet Appearance

## 1.2.1

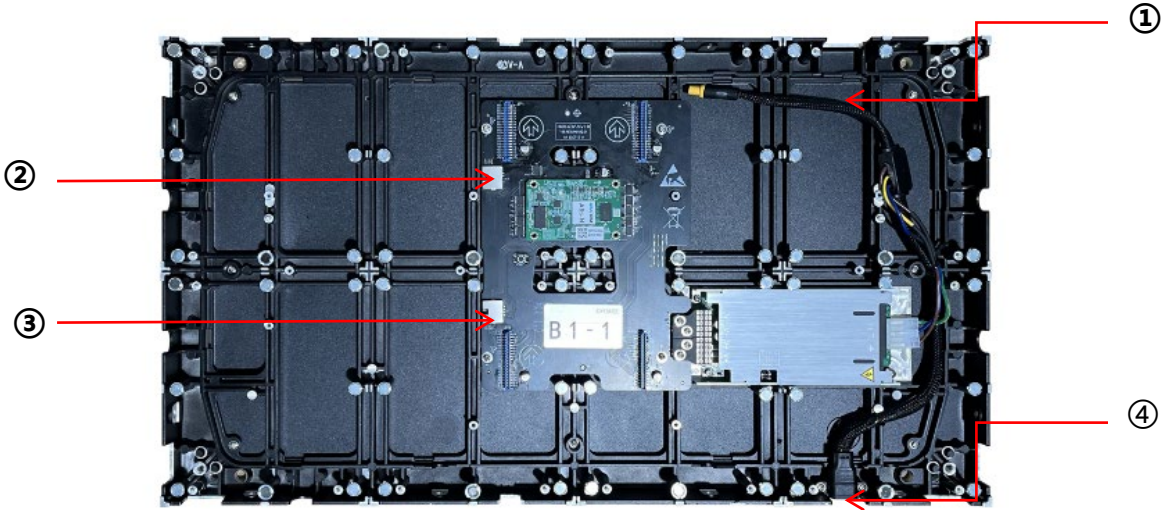

Fig 1-1

No	Descriptions
①	Power Output Terminals
②	Output Network Cable
③	Input Network Cable
④	Power Input Terminals

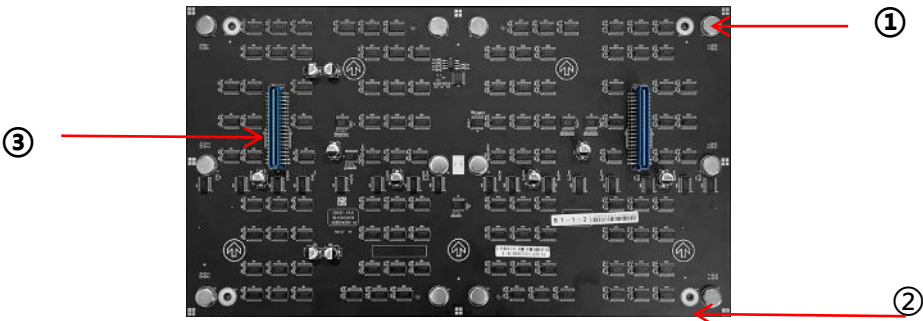

Fig 1-2

No	Descriptions
①	Sheet Iron Light Plate
②	Copper Locating Column
③	Power Supply and Signal Interface

### 1.3 Detailed Product Drawing

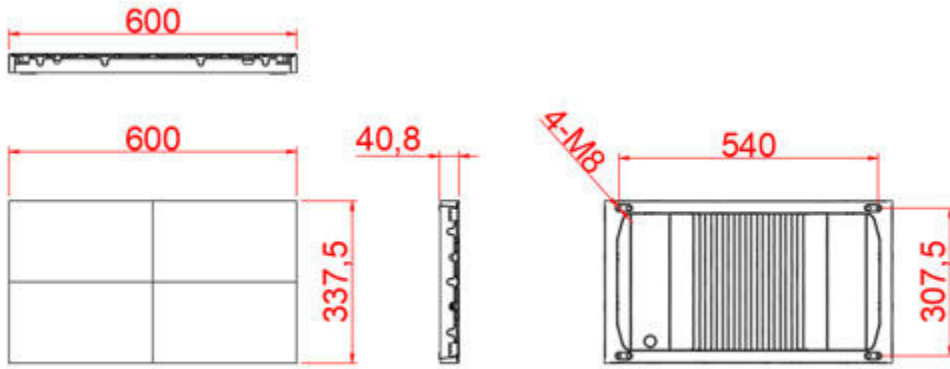

Figure 1-3



Figure 1-4

## 1.4 Internal Components of the cabinet:

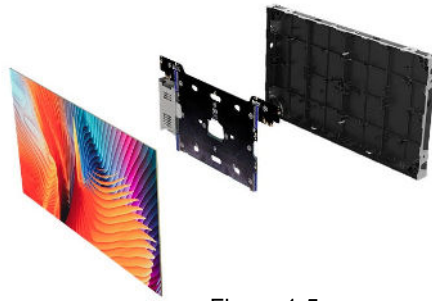

Figure 1-5

Name	quantity
LED Module	4
Power Signal Converter Board	1
Power Supply	1
Power Connector	2
Signal Port (RJ45 Network Port)	2

■ The interface of the receiving card is shown below:

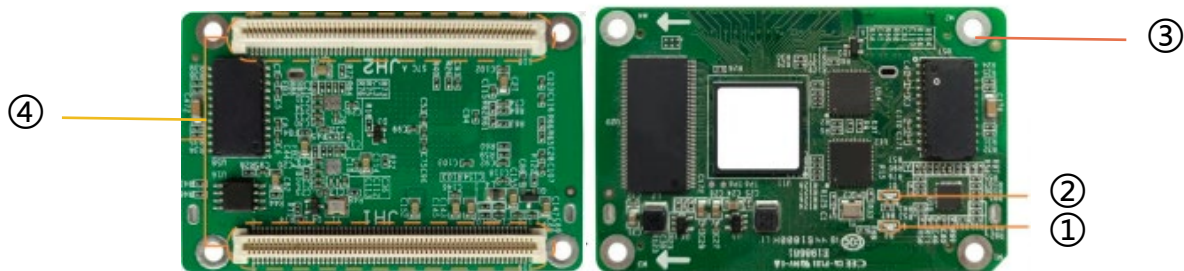

Figure 1-6

No	Description
①	Power Indicator: A steady red light indicates the power supply is normal.
②	Signal Light: The green light blinks rapidly (5 to 10 times per second), indicating normal data transmission.
③	Fix the hole positions to reinforce the receiving card and enhance its anti-vibration capability.
④	The Goldfinger Interface: Used to connect to the screen adapter or unit board. The front left guide is the first pin, as shown in the figure above.

## Chapter 2: Installation and Wiring

### 2.1 Out-of-cabinet Inspection

Inspect the packages for damage. If intact, verify the main components against the shipping list.

The main components include cabinets, signal cable, power cable, USB cable, DVI cable, and sending cabinet. For details about the components, refer to the shipping list.

#### Common cables include:



Power Cables



HDMI cables



signal input cables



USB cables



DisplayPort (DP) cables



DVI cables

Fig 2-1

## 2.2 Common tools

Common tools for LED installation preparation (the actual delivery may vary; the picture is for reference only):



Hexagon socket head cap screws



Allen key



Rubber Hammer



Connector (or Coupling Piece)



Grinder (or Sander)



Gloves (or Mittens)

Fig 2-2

## 2.3.1 Cabinet layout:

1. Open the packing cabinet and verify the number of each item. Locate the accessory cabinet (including installation tools, screws, connectors, etc.).
2. Remove the cabinets and arrange them according to their number. Ensure the correct cabinet size as shown in Figure 2-3.

**(This sorting method is based on calibrated cabinets; if no calibration is available, sort according to the actual delivery order.)**

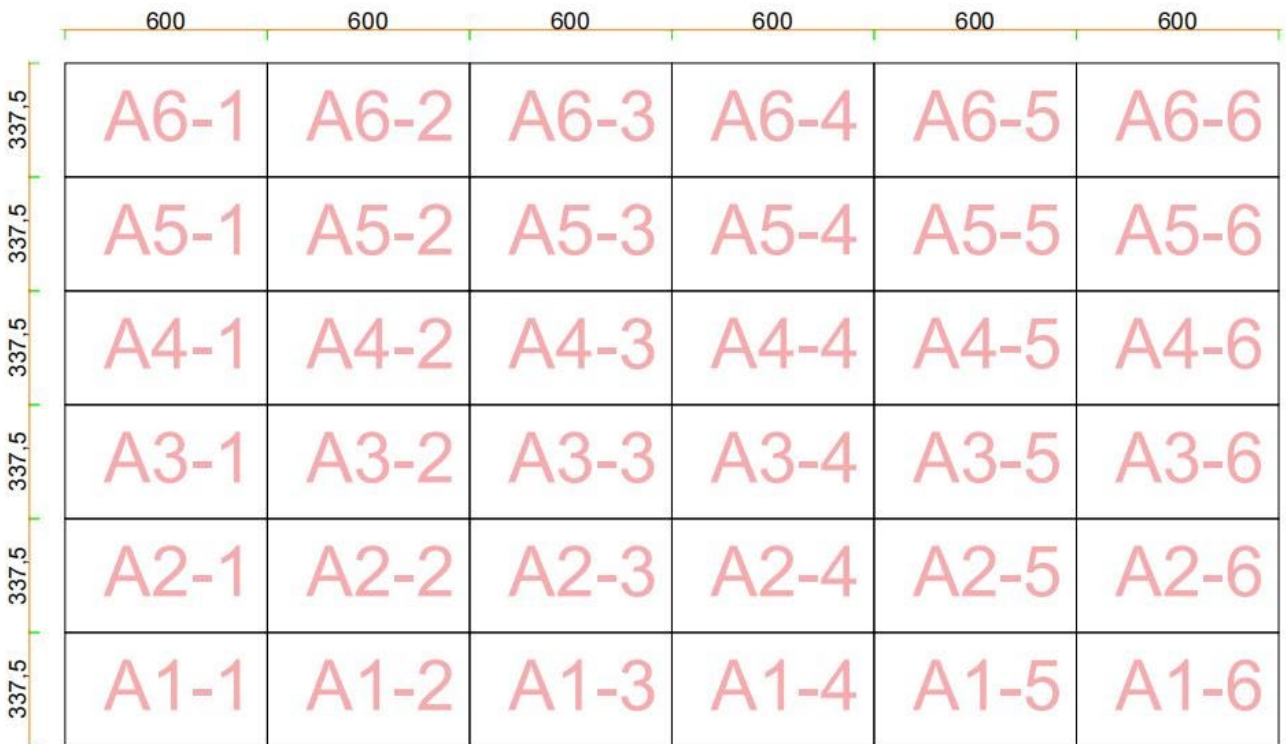

Figure 2-3

## 2.4 Ground Installation Process:



**Warning:** The flatness tolerance of the 63V series cabinet splicing display screen must be within  $\pm 0.1\text{mm}$  and kept vertical to the reference plane.

1. First, assemble the cabinets in the first row and adjust them to ensure they are level. The foundation of the first row is crucial.
2. After leveling, tighten the locks inside the left and right cabinets.
3. Secure the connection between the back of the cabinet and the connector with screws

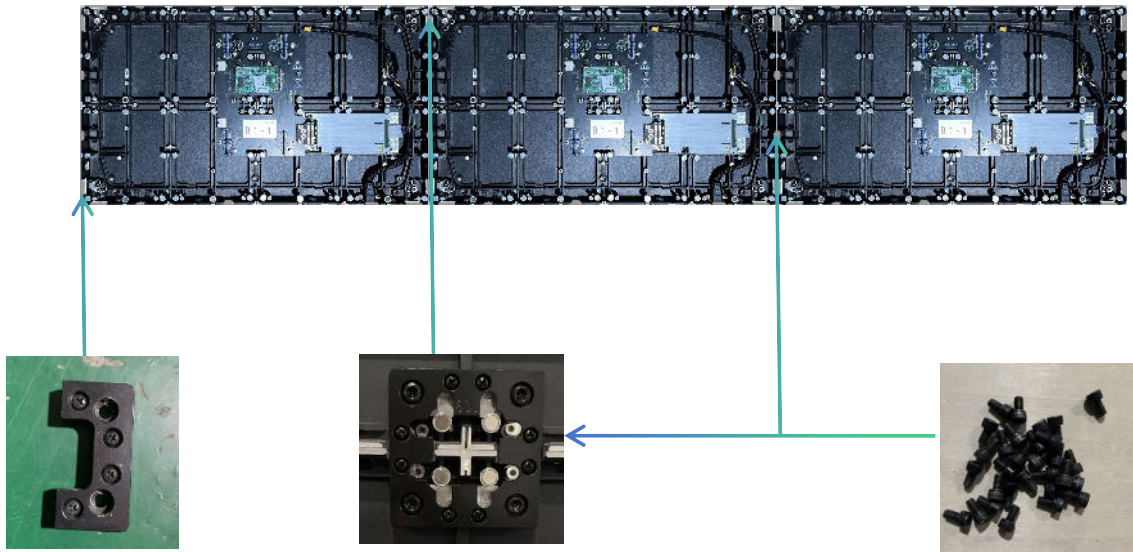

Front view

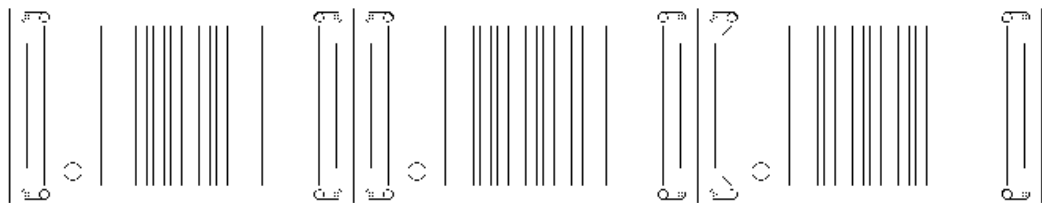

Back view

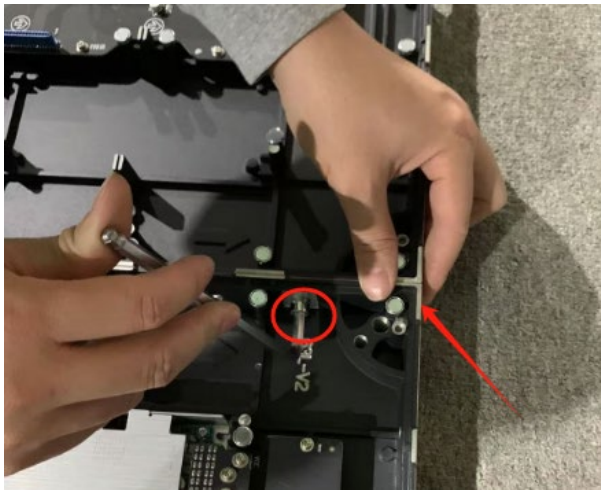

1. Use hex socket screws to tighten the cabinet joints and ensure the cabinet's flatness remains within  $\pm 0.1\text{mm}$  while locking.

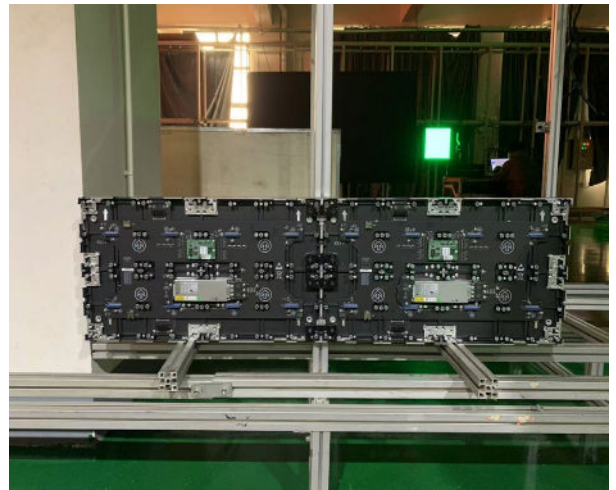

2. Place the cabinets on the ground, aligning the center of the two cabinets with the square tube to ensure they are level.



3. Use long connecting pieces and screws to secure the cabinets.

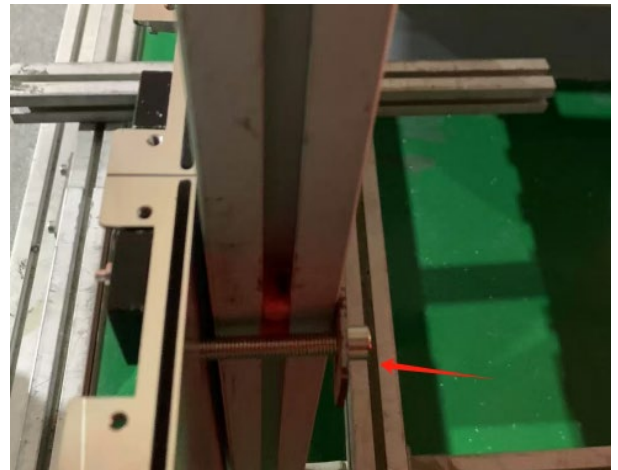

4. Use long connecting pieces and hex socket screws to secure the cabinet and square tube.

5. After securing the first row of cabinets, fix them starting from the middle and then install the left and right sections

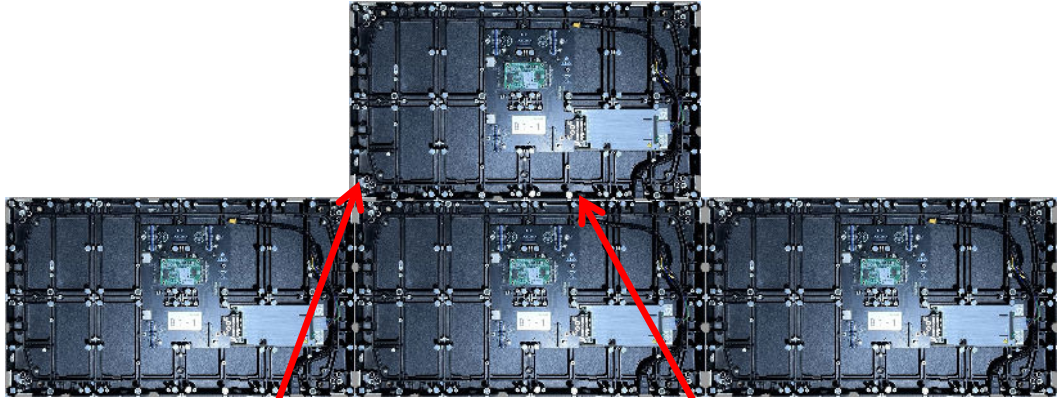

6. Secure the front connecting piece.

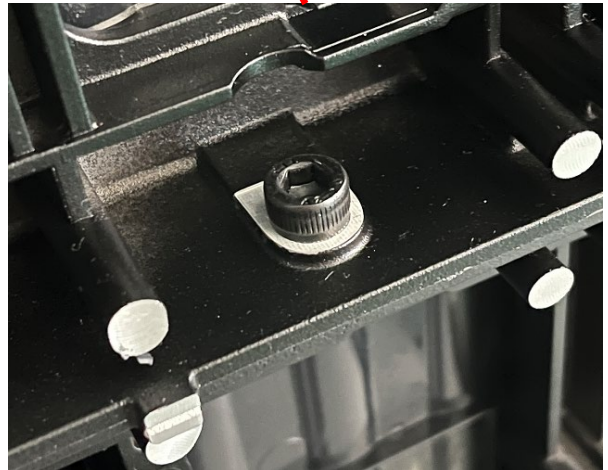

7. Continue tightening the hex socket screws that connect the upper and lower parts of the cabinet.

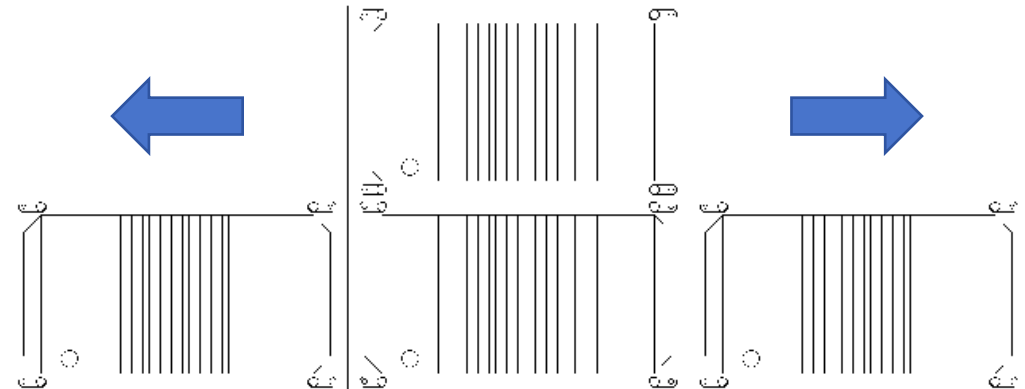

8. Continue securing the rear connection piece.

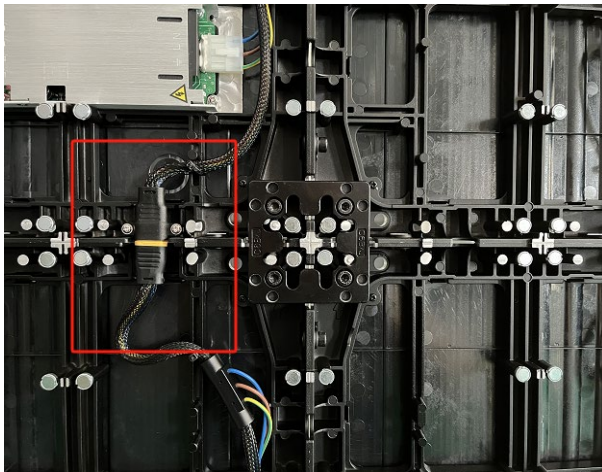

9. Install the power connector between the cabinets

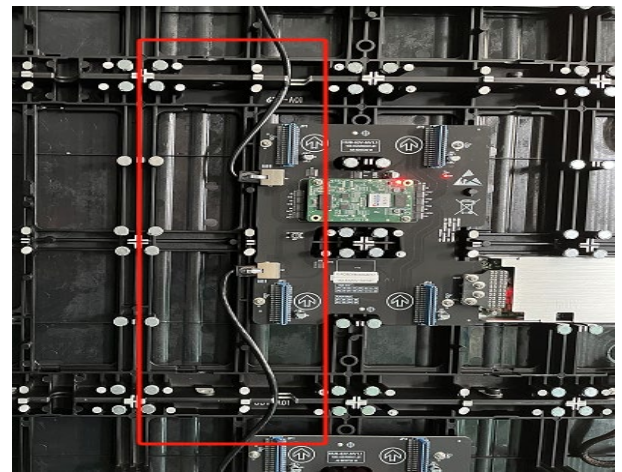

10. Install the short network cables between the cabinets.

**Note:** After installing the connectors, verify the flatness of the connection and ensure the signal cable is properly connected. Once confirmed, connect the long signal line and cables according to the installation diagram.

## 2.5 Back frame structure

1. The installation structure depends on site conditions.

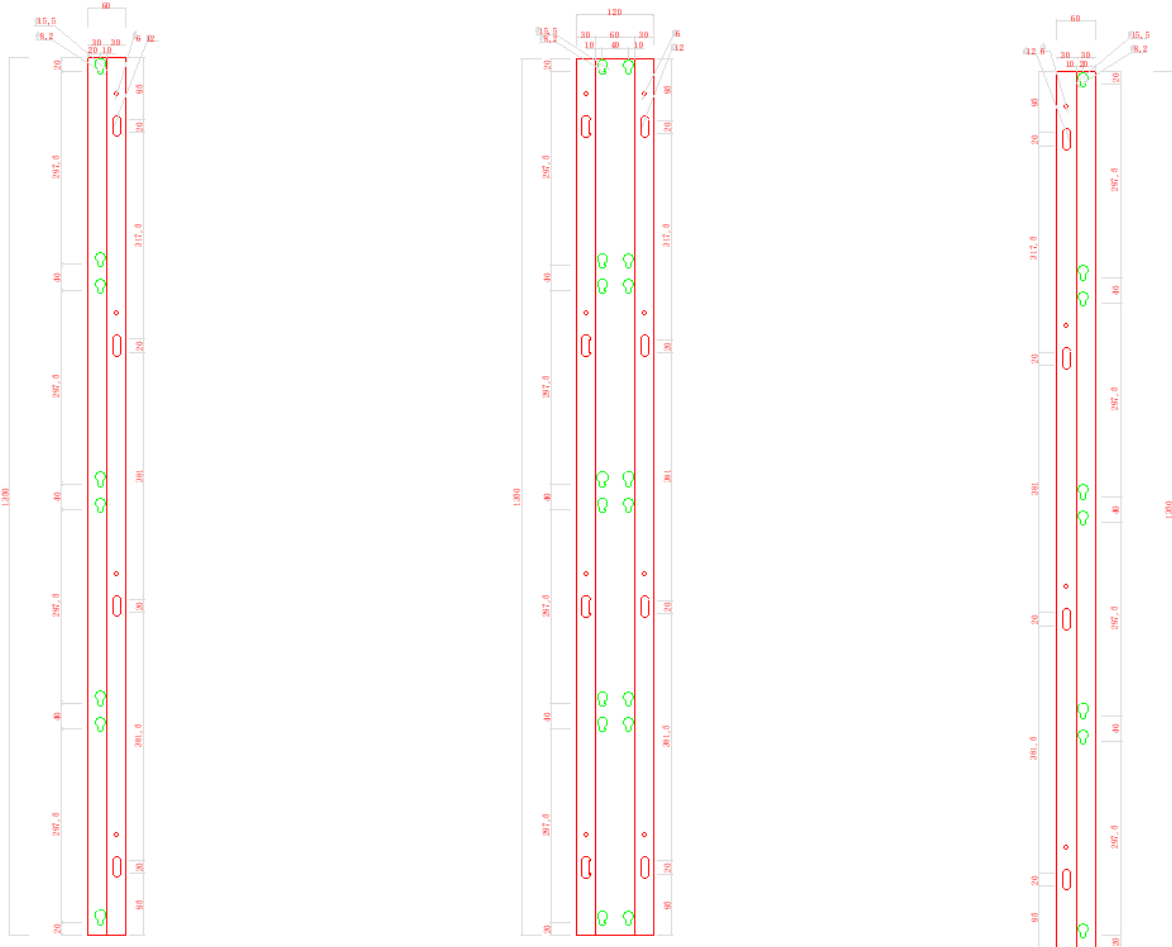

Left

Middle

Right

Note: The sizes of mounting brackets and hole positions may vary between products, but the installation methods are similar.

## 2.6 Back Frame Installation: (See steel structure design and installation drawing for details)



1. Use a level or laser to check the alignment and mark the distance.

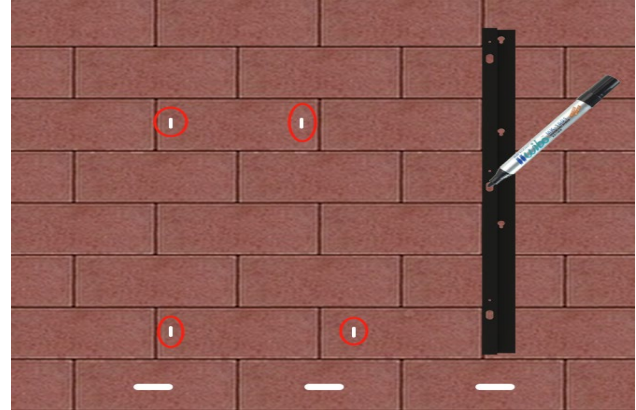

2. Position the wall mount according to the horizontal mark, ensuring the screws are correctly positioned and marked.

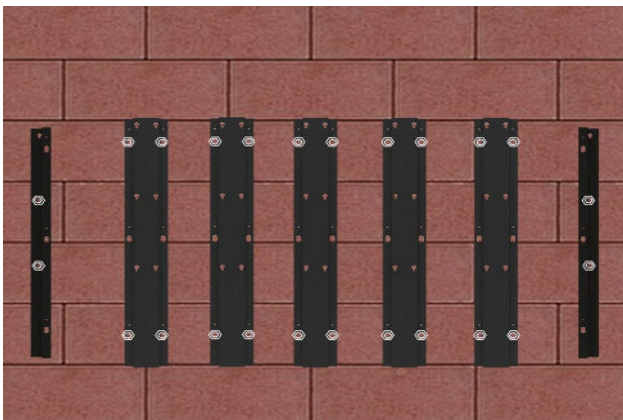

3. Use expansion screws to secure the marked points.

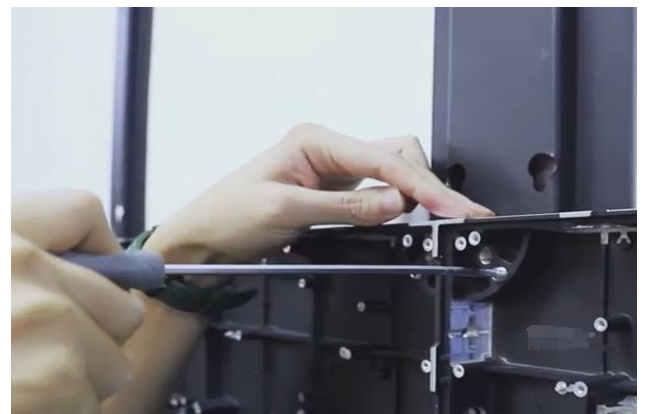

4. Secure the cabinet in the larger hole with set screws, then use a hex key to tighten the screws and mount it onto the bracket



5. Install the front connecting piece between the cabinets

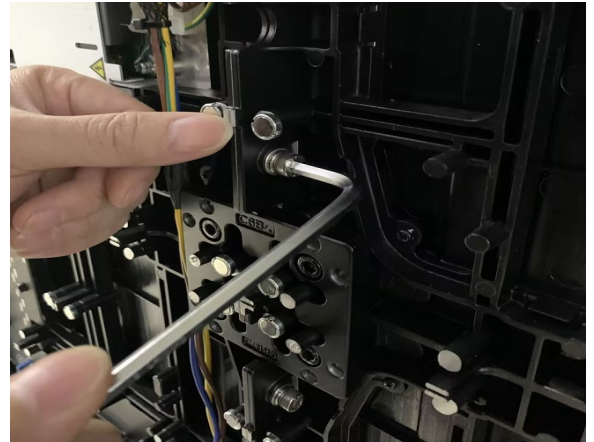

6. Use M5 screws to secure and ensure the top and bottom are level. The tolerance must be within  $\pm 0.1\text{mm}$ .

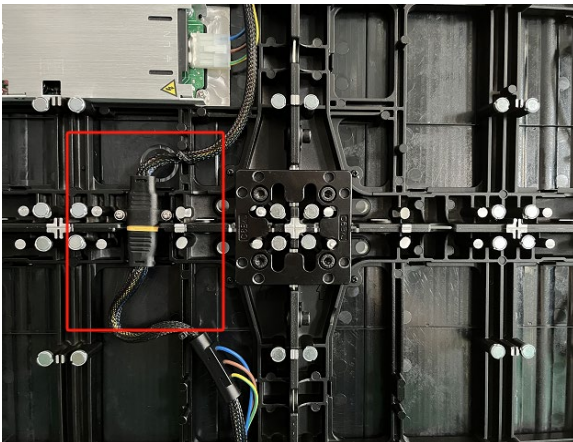

7. Install the power connector between the cabinets

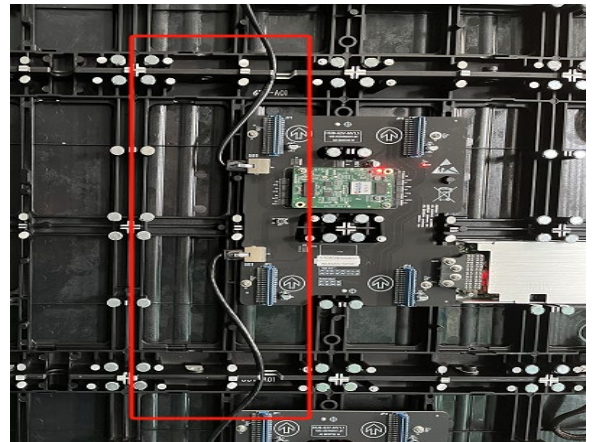

8. Install short network cables between the cabinets.

After installing the connector, verify the flatness of the connection and ensure the signal cable is properly connected. Once confirmed, connect the long signal line and cables according to the installation diagram.

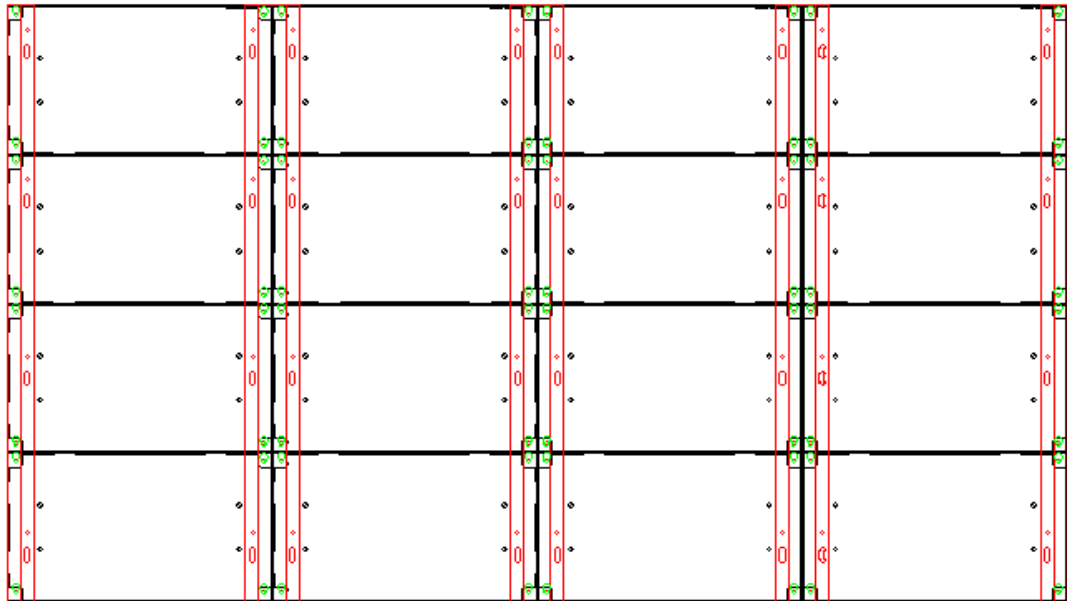
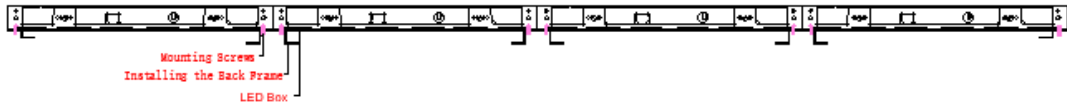
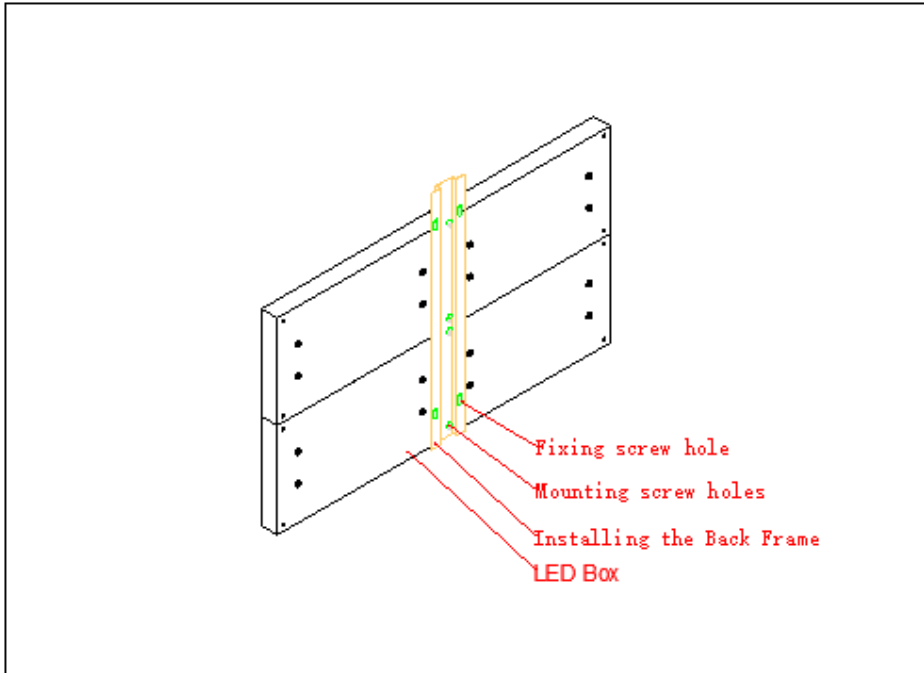

## 2.7 Signal Cable Connections

The signal cable connection should be made according to the wiring diagram provided with the project delivery.

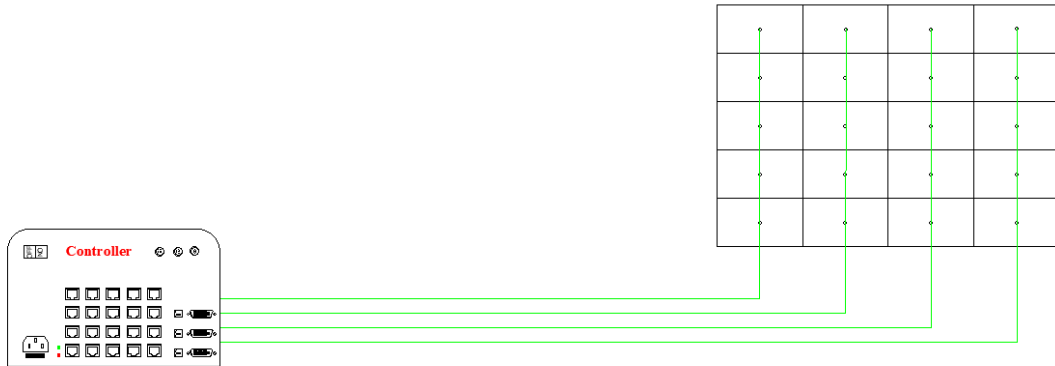

**Cat 6 network cable - 4 pcs Tencent distance  $\leq 100\text{m}$**

Fig 2-12 Signal Cable Connection Diagram of P1.2

## 2.8 Power Cable Connections

The power cable connection should be made according to the wiring diagram provided with the project delivery.

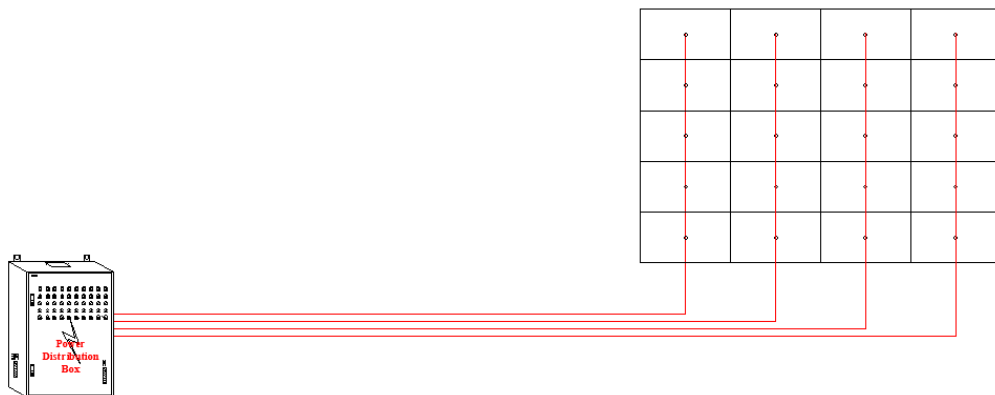

**110~240V / RVV3\*2.5mm<sup>2</sup> National standard pure copper cable 4 pcs**

Fig 2-13 Power Cable Connection Diagram of P1.2

## 2.9 Module Layout

Screen calibration is performed on the series product before shipment, and the installation should proceed sequentially according to the cabinet number, as shown in Figure 2-11:

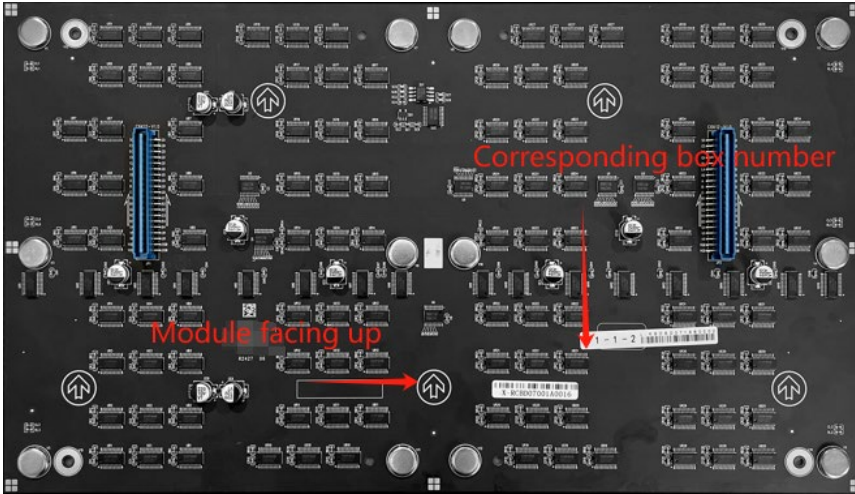

Fig 2-11 Front View of the Display

## 2.10 Intelligent control distribution cabinet

The Smart Control Distribution cabinet can be used for distributing electric power to the LED display, and has the function for real-time monitoring of the temperature, humidity, smoke, and mains voltage of the external environment. The control software has the scheduled start/stop function, allowing you to set any time for the LED display to be remotely started or stopped

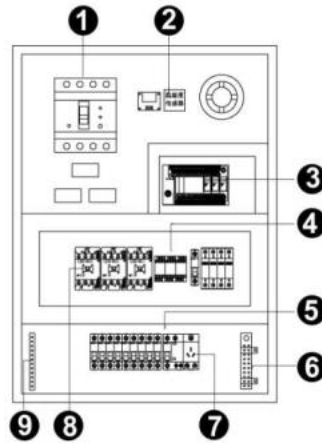

Fig 2-25 Internal Structure of Distribution cabinet

SN	Component	Remark (s)
1	Main switch	MCCB
2	Temperature sensor	Used for temperature detection
3	PLC	Used for smart control
4	Relays	Used to control the ON/OFF of the AC contactor
5	Circuit breaker	MCB, Connect to display live wire
6	Neutral wire socket	Connect neutral wire
7	Power Port	/
8	AC Contactor	Used to control the ON/OFF of the current
9	Earth wire socket	Connect earth wire

The PLC communication system is RS485, It uses converter from control computer RS232 to RS485. For more detail information, please refer to our Intelligent Power Distribution Management System Manual.

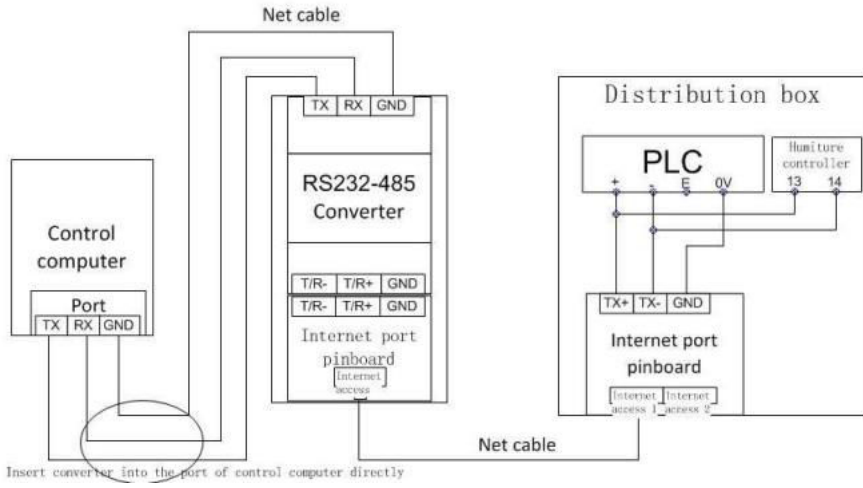

Fig 2-26 Distribution Cabinet PLC Connection Diagram

## 2.11 Load Calculation

### 2.11.1 Total Display Power

Total display power = total cabinet power + peripheral device power + cooling device rate

#### ■ Switching Power Supply

Single supply power (W) = output voltage (V) \* Output current (A)

#### ■ Total Cabinet Power

- Total Number of Cabinets \* Cabinet Power
- Total cabinet area \* Maximum power per square \*120% (reserved for switching power supply)

**i** Note: For details about the maximum power per square cabinet, see the device parameters of

the corresponding cabinet model. For details, see 1.3 Device Parameters

#### ■ Total Power of Peripheral Device

The processor and lighting equipment behind the screen are about 2KW.

#### ■ Total Power of the Heat Dissipation Device

Air conditioning power  $\approx 10\text{m}^2/\text{P} \approx 800\text{W}$ . For example, a  $30\text{m}^2$  cabinet screen requires a 3P cooling air conditioner, then the total cooling power is  $800\text{w} * 3 = 2.4\text{kw}$ .

### 2.11.2 PDC Cable Model Selection

Table 2-1 Mapping to PDC Cable Models

PDC Model	Incoming Cable Model	Maximum Currency(A)	Minimum Tube (mm)
10KW PDC	RVV5×6mm <sup>2</sup>	25	25
20KW PDC	YJV5×10mm <sup>2</sup>	55	50
30KW PDC	YJV5×10mm <sup>2</sup>	70	50
40KW PDC	YJV4×25+1×16mm <sup>2</sup>	100	50
60KW PDC	YJV4×35+1×16mm <sup>2</sup>	125	65
80KW PDC	YJV4×50+1×25mm <sup>2</sup>	150	80
100KW PDC	YJV4×70+1×35mm <sup>2</sup>	190	80
120KW PDC	YJV4×95+1×50mm <sup>2</sup>	235	80
120KW PDC	YJV4×120+1×70mm <sup>2</sup>	265	100
150KW PDC	YJV4×150+1×70mm <sup>2</sup>	300	120
180KW PDC	YJV4×180+1×95mm <sup>2</sup>	360	150

# Chapter 3: System Solution Overview

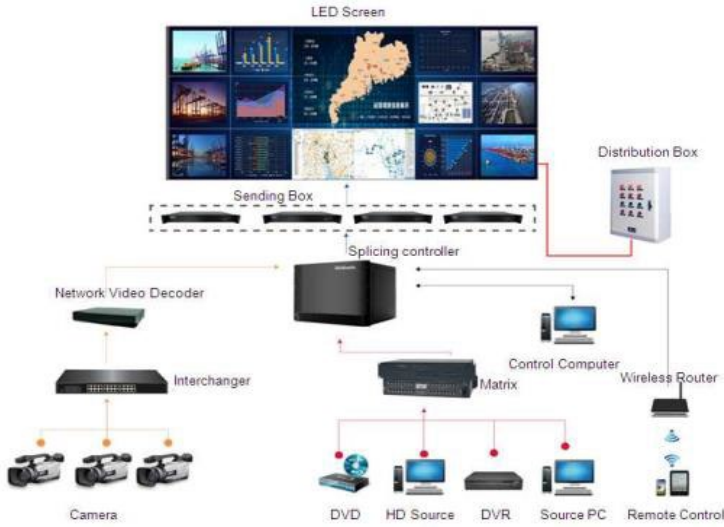

Fig 3-1

## 3.1 Scope of Application

The series products can be seamlessly assembled into screens of any size and are widely used as fixed LED display screens for advertising in public spaces, such as conference rooms, command centers, and control rooms.



Control Room

Meeting Room



Monitoring Room

Training Room

Fig 3-2



### 3.2 Specifications:

The equipment parameters for small-pitch LED unit cabinets are shown in the table below:

Name		P0.9	P1.2	P1.5	P1.8
Module Composition	Pixel Structure	COB	COB	COB	COB
	Pixel Pitch(mm)	0.93	1.25	1.56	1.87
	Module Resolution(W×H)	320*180	240*135	192*108	160*90
	Module Size(mm)	300*168.75			
Unit Cabinet Composition	Unit Module Composition(W×H)	2*2			
	Module Resolution(W×H)	640*360	480*270	384*216	320*180
	Unit Size (mm)	600*337.5			
	Unit Area(m <sup>2</sup> )	0.2025			
	Unit Weight(kg/unit)	3.9			
	Pixel Density (pixels/m <sup>2</sup> )	1137777	640000	409600	284444
Optical Parameters	Point Brightness Correction	Support支持			
	Single Point Color Correction	Support			
	White Balance Brightness (nits)	0-600			
	Color Temperature(K)	2000~12000			
	Horizontal View Angle(°)	170			
	Vertical Viewing Angle(°)	170			
	Distance Deviation of Light Point Center	< 3%			
	Luminance Uniformity	≥98%			
	Chroma Uniformity	±0.0035 Within Cx,Cy			
	Contrast Ratio	10000:1			

Name		P0.9	P1.2	P1.5	P1.8
Electrical Parameter	Peak Power Consumption (W/m <sup>2</sup> )	300		270	
	Average Power Consumption (W/m <sup>2</sup> )	120		100	
	Power Supply Input	AC100~240V (50-60Hz)			
	Frame Frequency (Hz)	50&60			
	Refresh Rate(Hz)	≥3840			
	Operating Temperature (°C)	-10 ~ +45			
	Storage Temperature (°C)	-20~60			
	Operating Humidity (%)	10~80 anti-fog			
	Storage Humidity (%)	Storage : 10~80%			
Maintenance	Maintenance Type	Front Maintenance			

## Chapter 4: LED Display Control Settings

### 4.1 Power-on Testing

- ① Ensure all devices are properly connected before configuring the LED display.
- ② Before powering on the LED display, use a multimeter to test the live, neutral, and ground wires of the AC power supply to ensure they are properly connected.
- ③ Ensure the ground wire maintains reliable contact with the ground and is properly insulated from the live wire.
- ④ The connected power supply should be kept away from high-power equipment.
- ⑤ For 3-phase, 5-wire systems, distribute the load evenly across phases to maintain three-phase balance.
- ⑥ The input voltage must match the voltage requirements indicated on the cabinet's rating tag.
- ⑦ Connect the provided USB cable from the sending cabinet to the control PC's USB port.
- ⑧ Ensure cables for the LED display are connected according to the provided power and signal cable connection diagrams.

### 4.2 Preparation for Debugging

#### 4.2.1 Starting the System

- ① Start the control PC and load the Windows system.
- ② Activate the graphics card driver and set the control PC's graphics card to replication mode. Confirm that the green indicator on the sending cabinet blinks once per second.

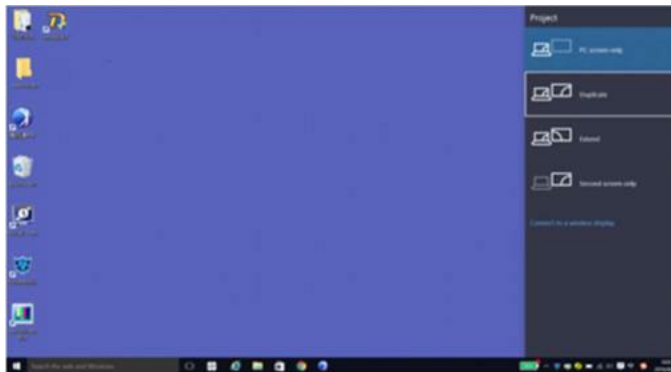

Fig 4-1 Replication Mode

#### 4.2.2 Installing the Software

Open the optical disk provided for the delivered products. Install the LED control software LCT stored in the optical disk to the control PC. Then install LCT



Fig 4-2 Software Installation

NOTE: You can follow the software installation wizard to install the software.

## 4.3 Display Configuration

Run LCT. Make sure that Control System on the main window is 1. Click the User option and select Advanced Login, as shown in Figure 4-3.

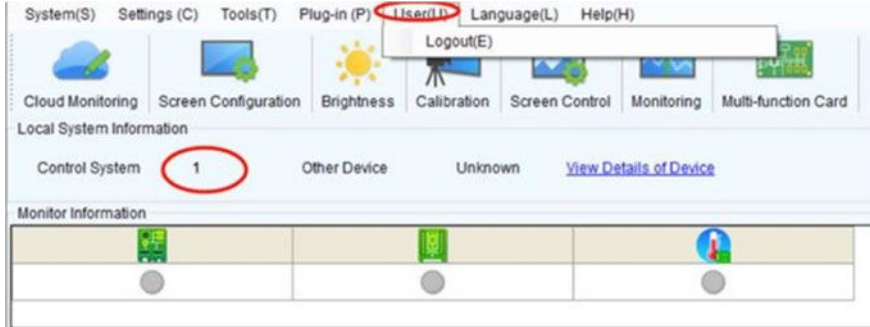

Fig 4-3 Main Window of LCT

Enter the initial password “admin”, as shown in Figure 4-4, to go to the advanced user window

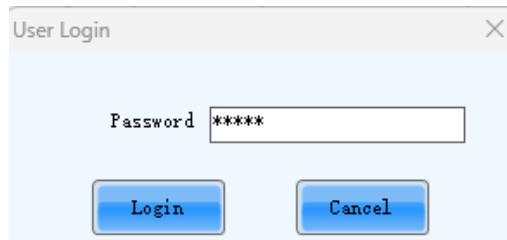

Fig 4-4 User Login

After login, click Screen Config on the main window, as shown in Figure 4-5



Fig 4-5 Main Window for Advanced User

Click Next, as shown in Figure 4-6:

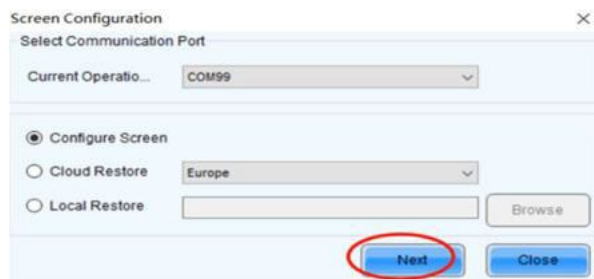

Fig 4-6 Screen Configuration

The following window is displayed. Set Sending Board Resolution (1920×1080 recommended). Set Graphics Output Resolution to the same value as Sending Board Resolution. Then click Save to save the settings.

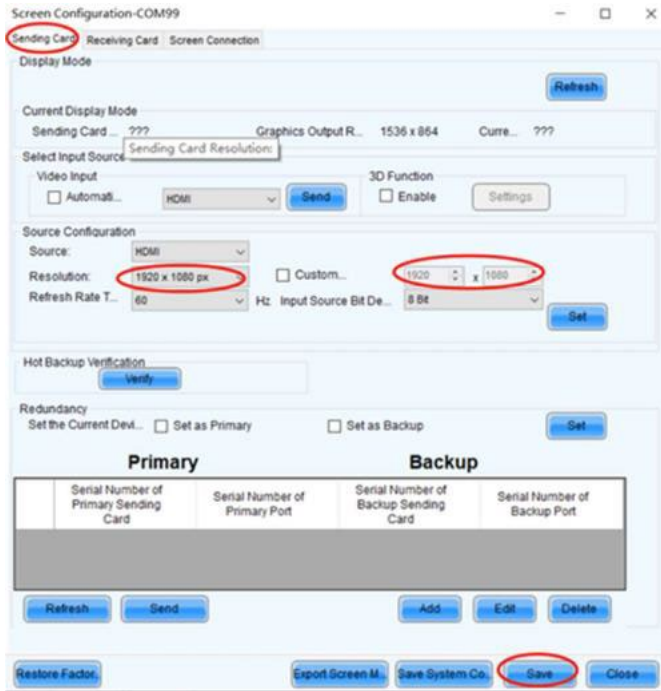

Fig 4-7 Sending Board Configuration

After configuring the parameters on the Sending Board page, click Receiving Card to display the following window:

- 1) Click Load From File to load the file xxxx.rcfg stored in the optical disk.
- 2) Click Send to Receiving Card.
- 3) After sending, confirm that the loaded picture received by scan board is normal on the screen. Then click Save.

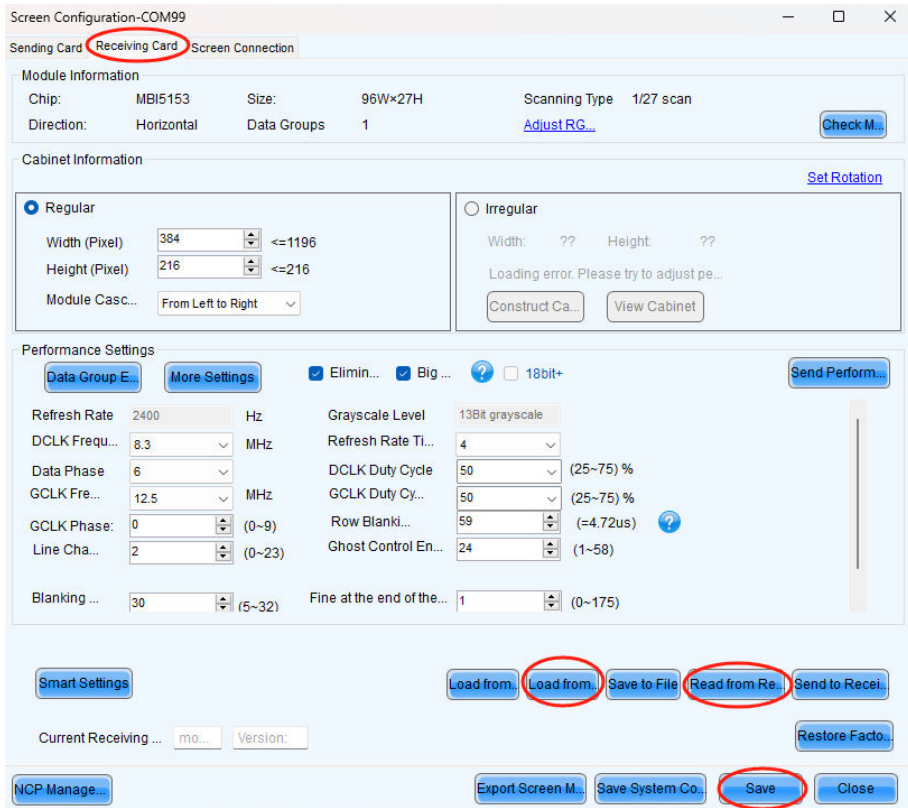

Fig 4-8 Scan Board Configuration

After configuring the parameters on the Scan Board page, click Screen Connection to display the following window:

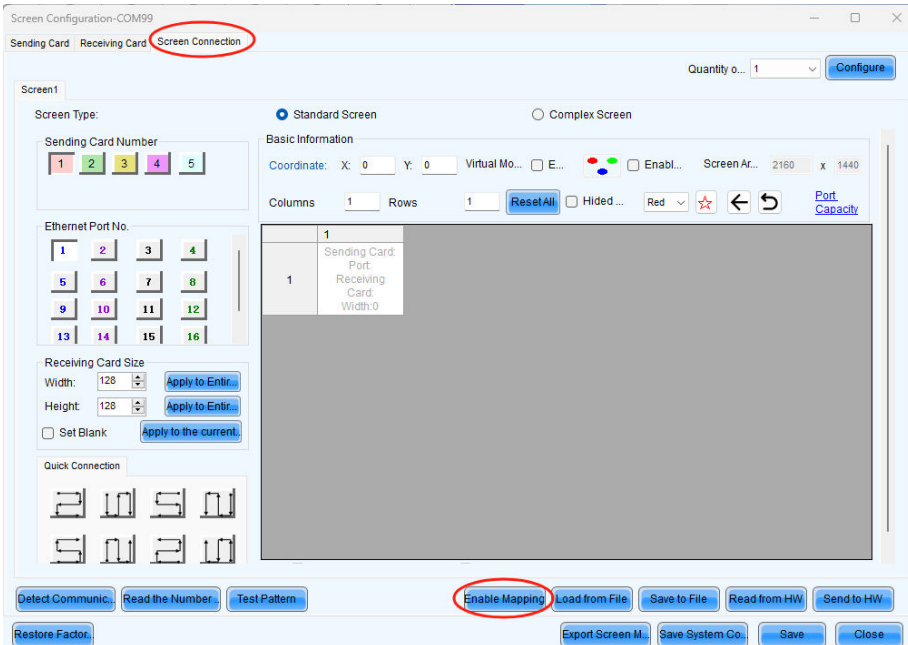

Fig 4-9 Screen Connection

- 1) Click Read File to load the file xxx.scr stored in the optical disk, as shown in Figure 3-10.

- 2) Click Send to HW.
- 3) After sending, confirm that the screen is complete. Then click Save.

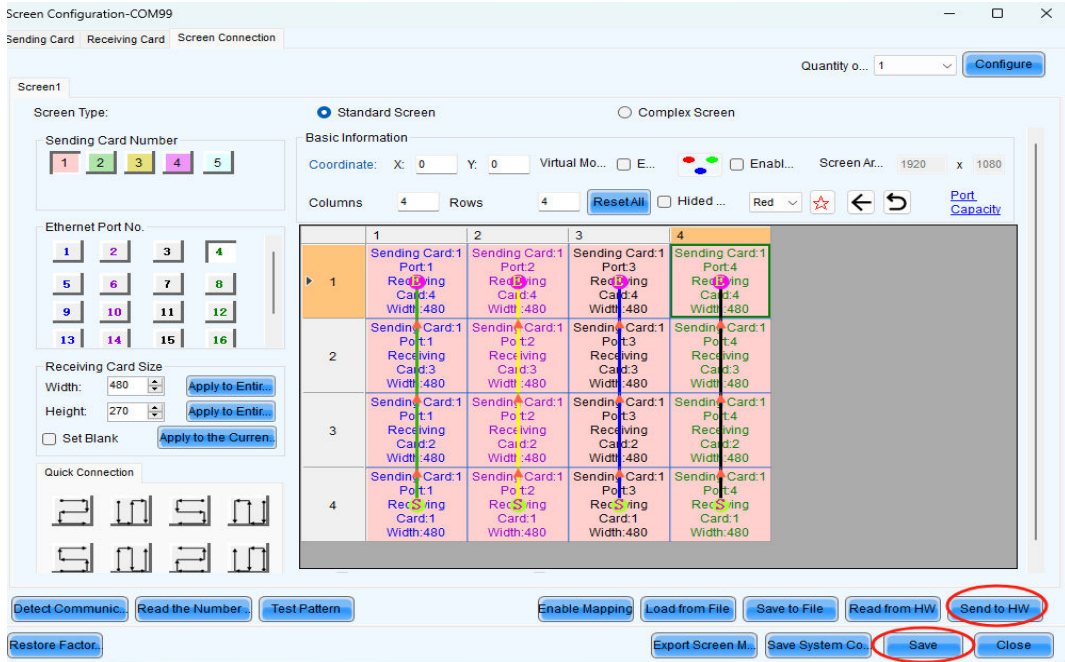

Fig 4-10 Screen Connection with Loaded File

## 4.4 Brightness Adjustment

On the main window, click **Brightness**, as shown in Figure 3-11, to display the brightness adjustment interface:

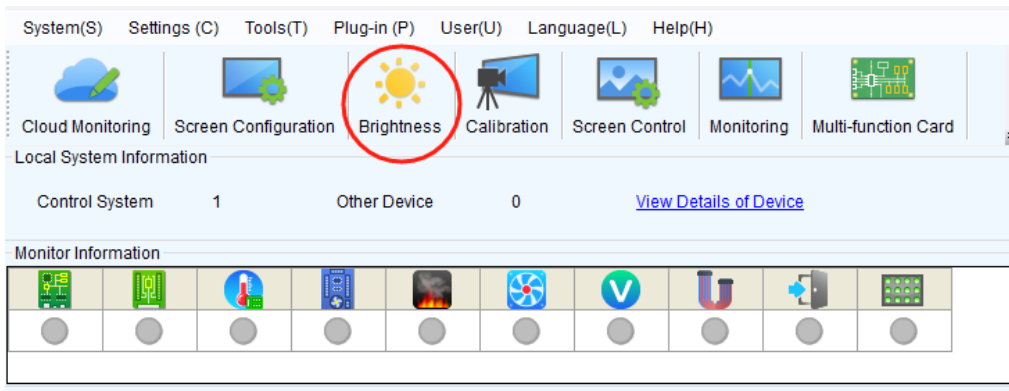

Fig 4-11 Main Window for Advanced User

There are four brightness adjustment modes, namely Manual, Schedule, Auto, and Auto Adjustment by Hardware. After adjustment is finished, click Save to HW to save the adjustment results to the hardware.

### 1.Manual Adjustment

Select Manual and adjust the brightness by dragging the scroll bar below Brightness Adjustment or directly modifying the brightness value (the maximum value is 255) next to the scroll bar.

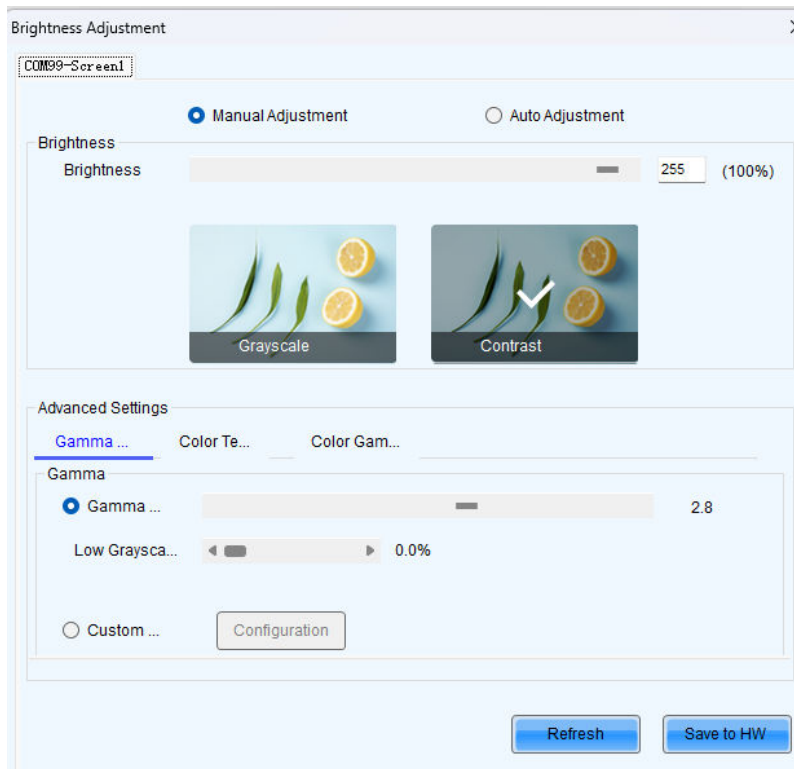

Fig4-12 Manual Adjustment

**Display Quality:** Includes Soft mode and Enhanced mode. The Soft mode is generally used for indoor LED displays while the Enhanced mode is used for outdoor LED displays.

**Gamma Adjustment:** Includes Mode A and Mode B. The LED display in Mode A can light up earlier than that in Mode B.

**Gain:** For chips with current gain function, adjusting the current gain can improve the chip's current output.

**RGB brightness:** Adjusts the brightness of Red (R), Green (G) or Blue (B) separately.

## 2. Automatic Adjustment

Schedule, Auto, and Auto Adjustment by Hardware are automatic adjustment modes. Automatic adjustment function is not recommended for indoor LED display products because the indoor environment has stable ambient light and is rarely affected by the ambient brightness. If you really need to use this function, you can configure this function by using the wizard.

## 4.5 Firmware Program Update

In the Screen Configuration interface, click Program Update. In the popup window, you can either click Cloud Update to match and install the firmware package automatically, or select and load a package manually. Alternatively, you can click Local Update to load and install the firmware package from your computer.

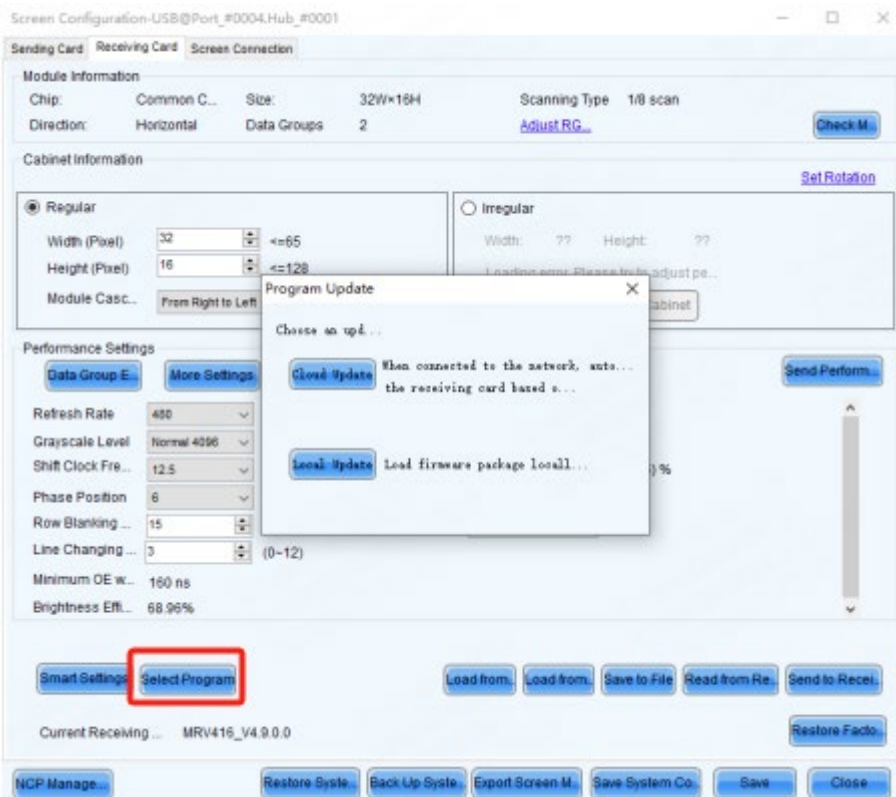

Fig4-13

## Operating Procedure

**Step 1:** On the menu bar, choose User > Advanced Synchronous System User Login. Enter the password and click Login.

The default password is "admin"

**Step 2 :** Type "admin" to open the program loading window as shown in

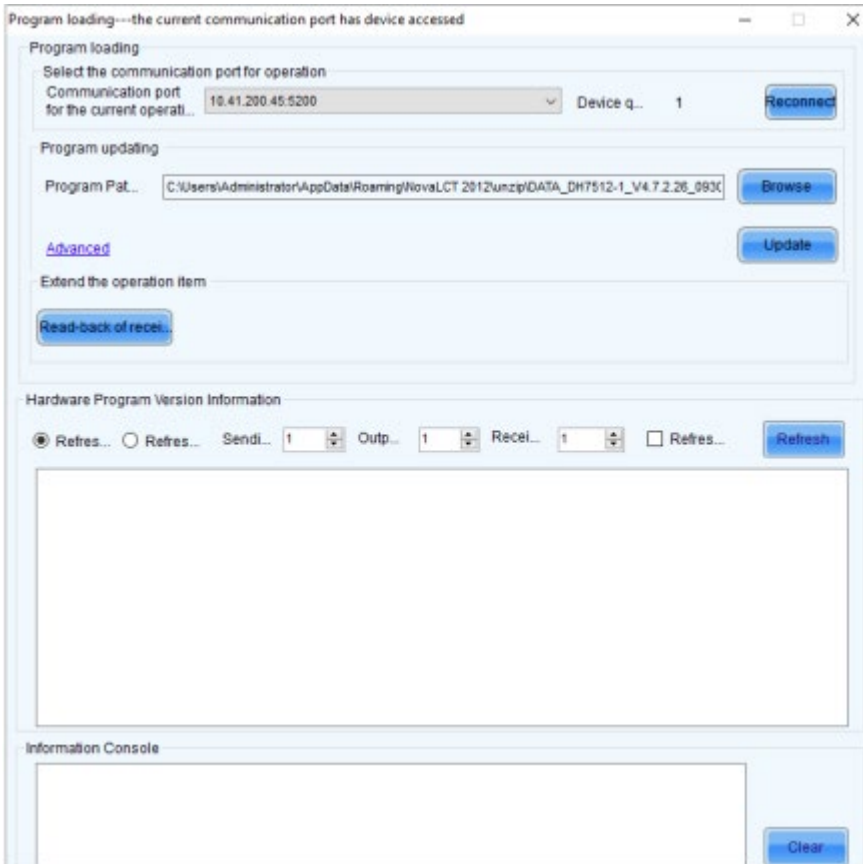

Fig4-14

**Step 3:** Choose a communication port.

If you need to reconnect the sending card, click Reconnect.

**Step 4:** Specify the viewing range and click Refresh to view the current program version of the hardware.

- Refresh All:** View the program versions of all the sending cards and receiving cards.
  - Refresh Specified:** View the program versions of the specified sending cards and receiving cards.
- If the module has an MCU, select Refresh Module MCU to view the MCU version.

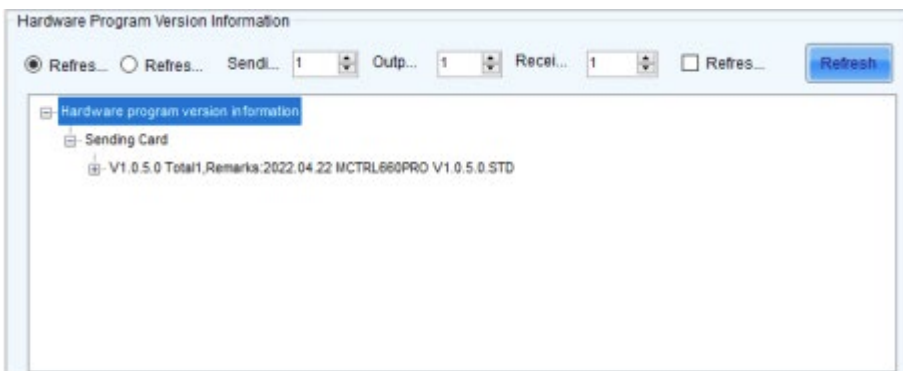

Fig4-15

**Step 5:** Click Browse, select a program package, and click OK. If you select an integrated firmware package for the receiving card (which includes firmware for multiple receiving cards), follow these steps:

In the Update Program interface, select the appropriate driver IC and decoding method based on your actual requirements, then either match the package file automatically or choose it manually, and click Update.

- Auto match: Select Auto Match, and the software will automatically select the appropriate package file based on the receiving card model, and the specified driver IC and decoding method.
- Manual selection: Unselect the Auto Match, and manually choose the required package file from the list

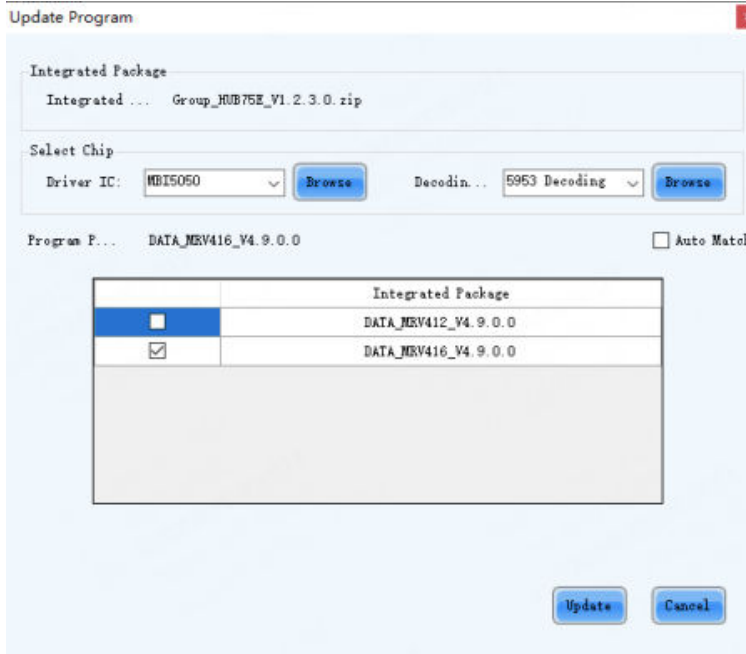

Fig4-16

**Step 6:** Click Advanced, select the items to be updated, and click OK.

**Step 7:** Click Update.

**Step 8:** Set to update the programs of all receiving cards or the specified receiving card, and then click OK.

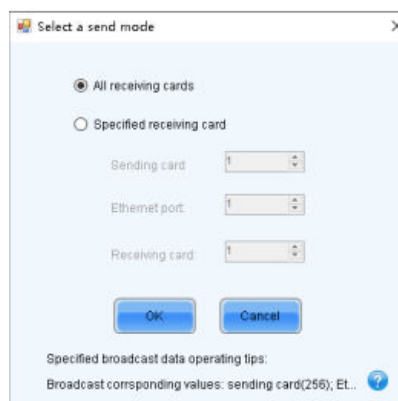

Fig4-17

**Step 9:** After the programs are updated successfully, click OK.

## 4.6 Send calibration data to the receiver card

**Step 1:** Click or choose Tools > Calibration from the menu bar.

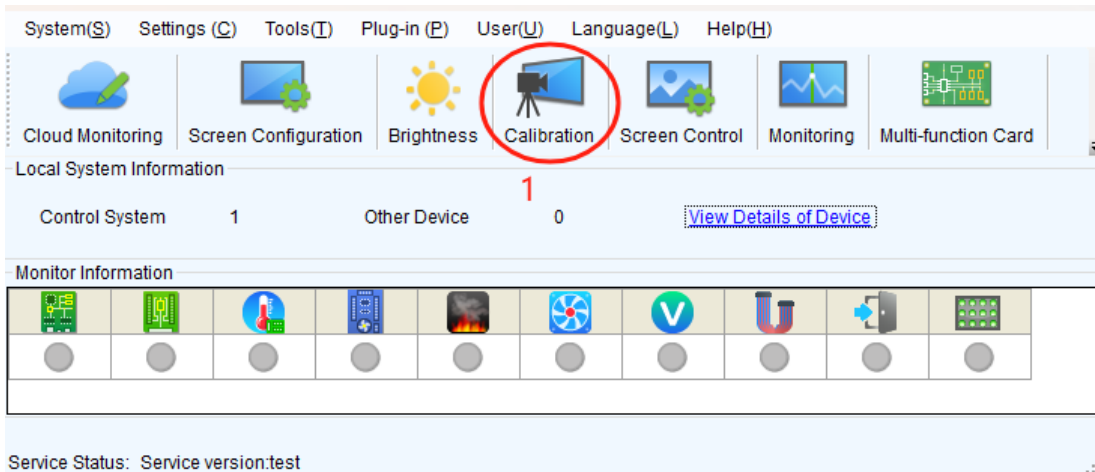

Fig4-18

**Step 2:** Select the Single-Screen Mode tab.

**Step 3:** Select the Manage Coefficients tab

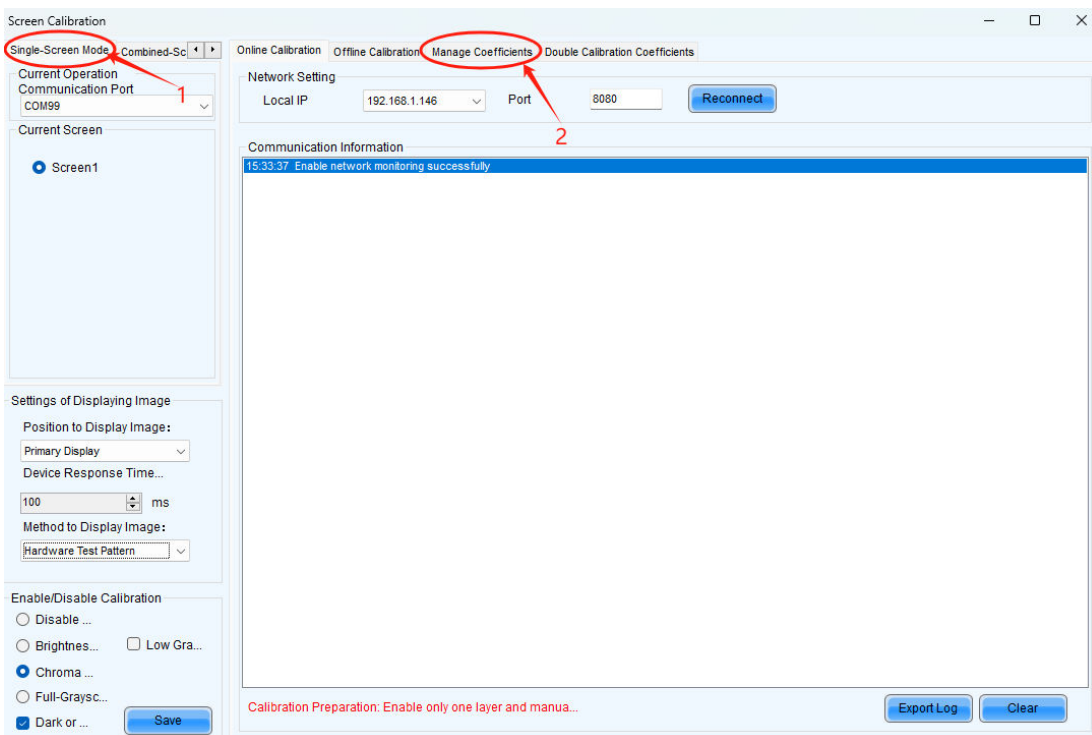

Fig4-19

**Step 4:** Click on the light board flash as shown

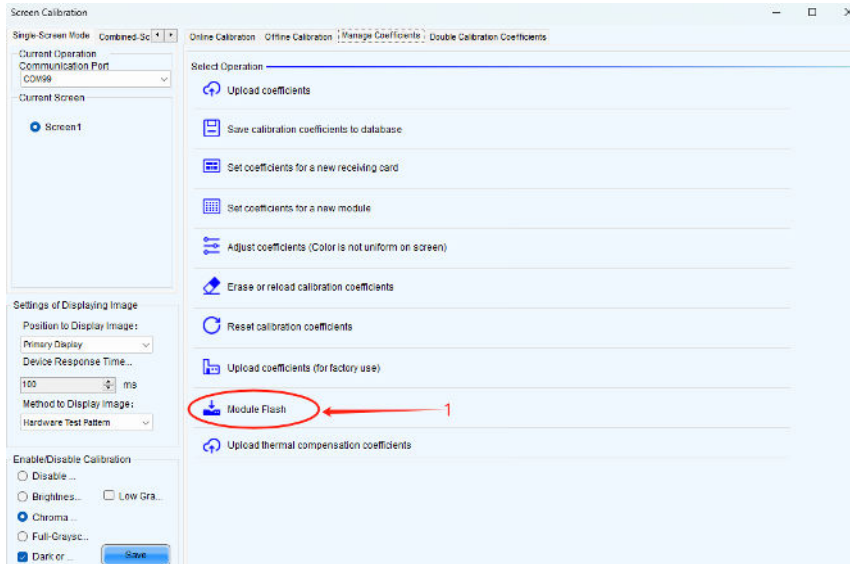

Fig4-20

**Step 5:** Click Flash Calibration, click View Lamp Board Calibration Factors, click Save Calibration Factors to Receiver Card, and click Cure.

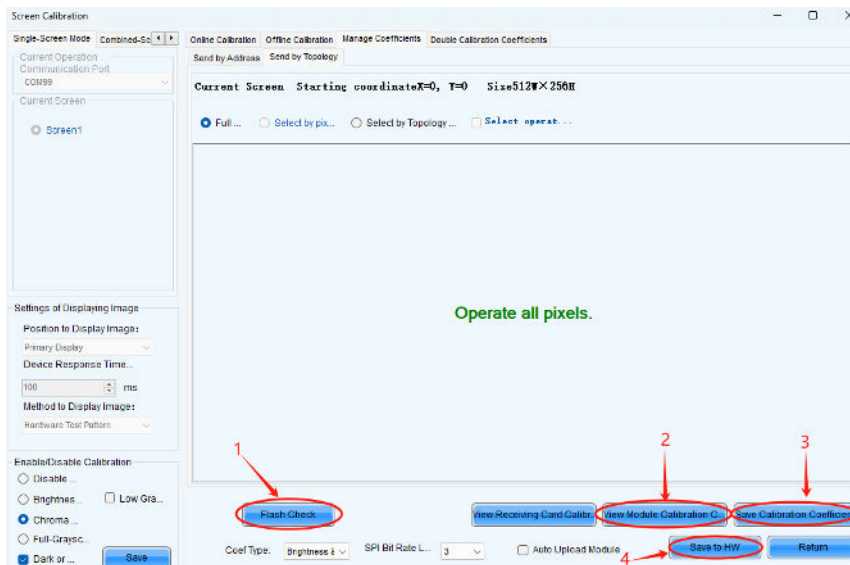

Fig4-21

# 4.7 Image Booster Engine

Step 1: Open as shown Image Booster Engine

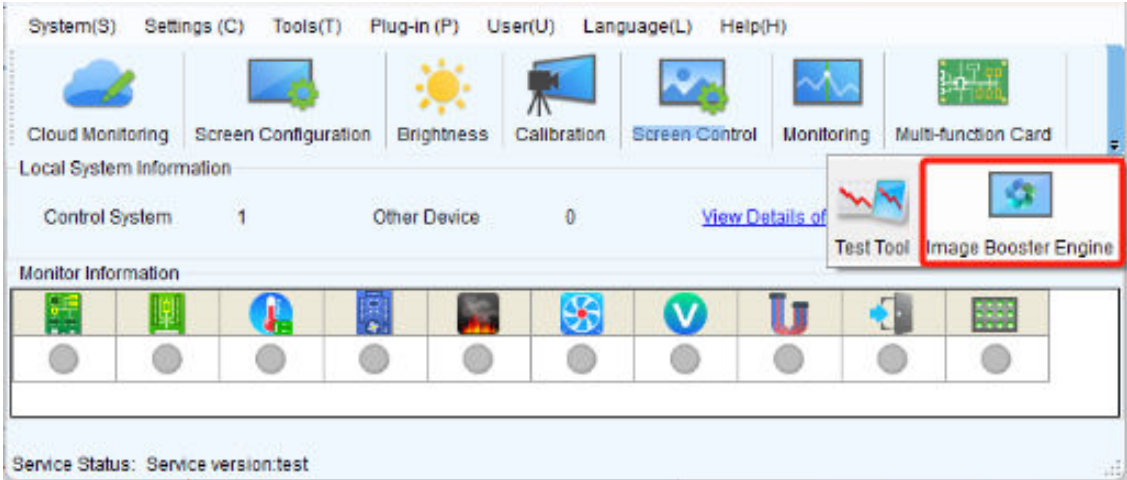

Fig4-22

Step 2: Colorimeter Connect

Step 3: Check the Hz value

Step 4: Automatic acquisition settings

Step 5: Start

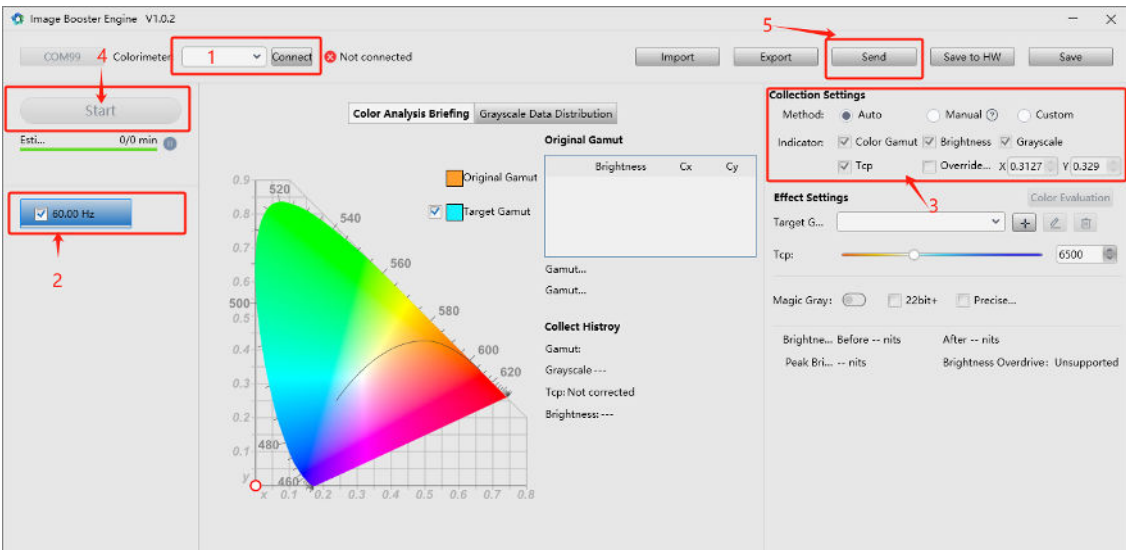

Fig4-23

## 4.8 Screen Play

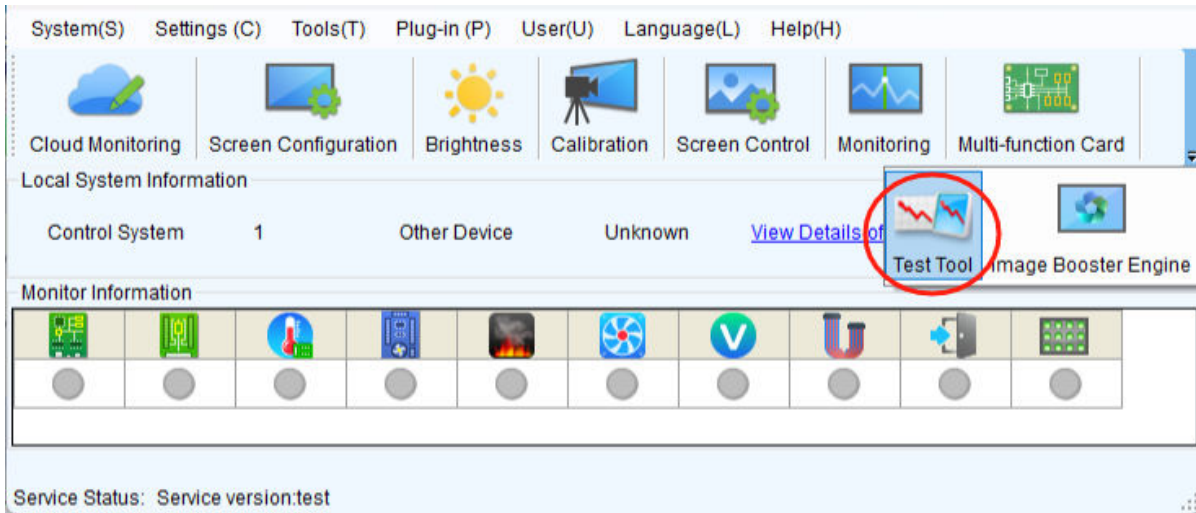

Fig 4-24 Test Tool

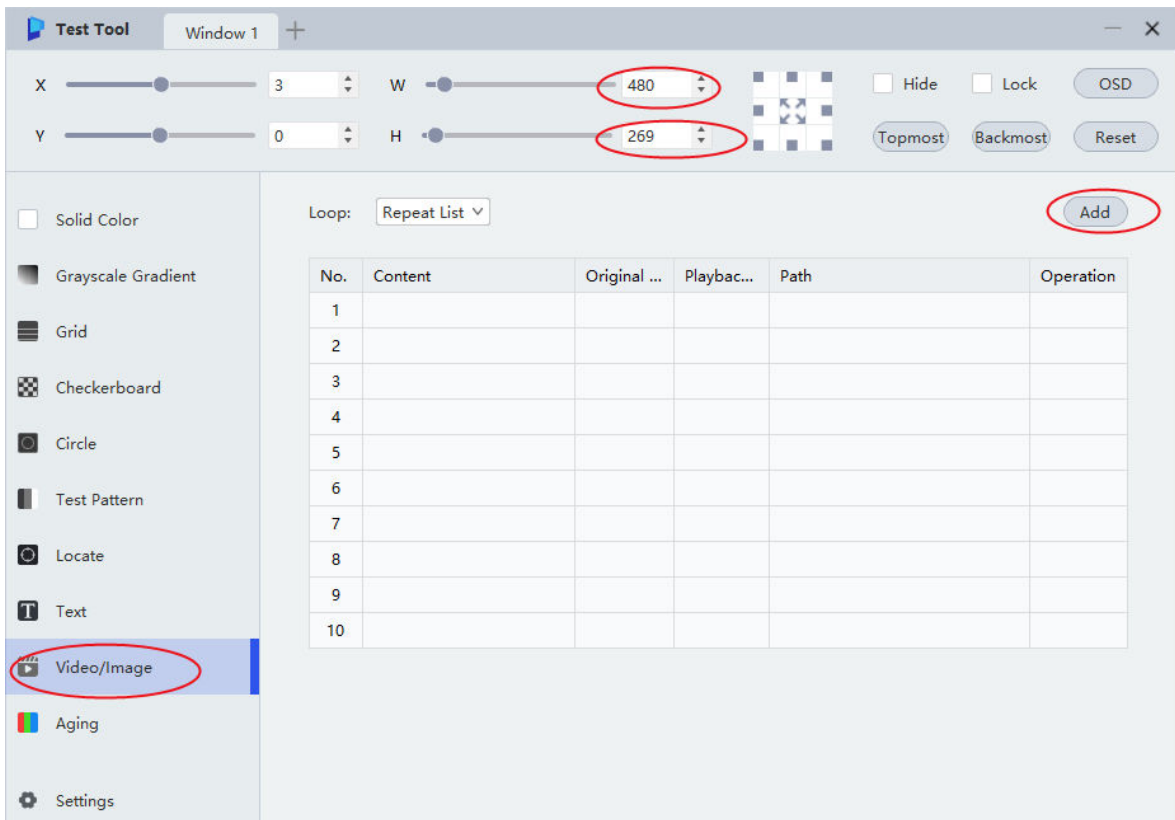
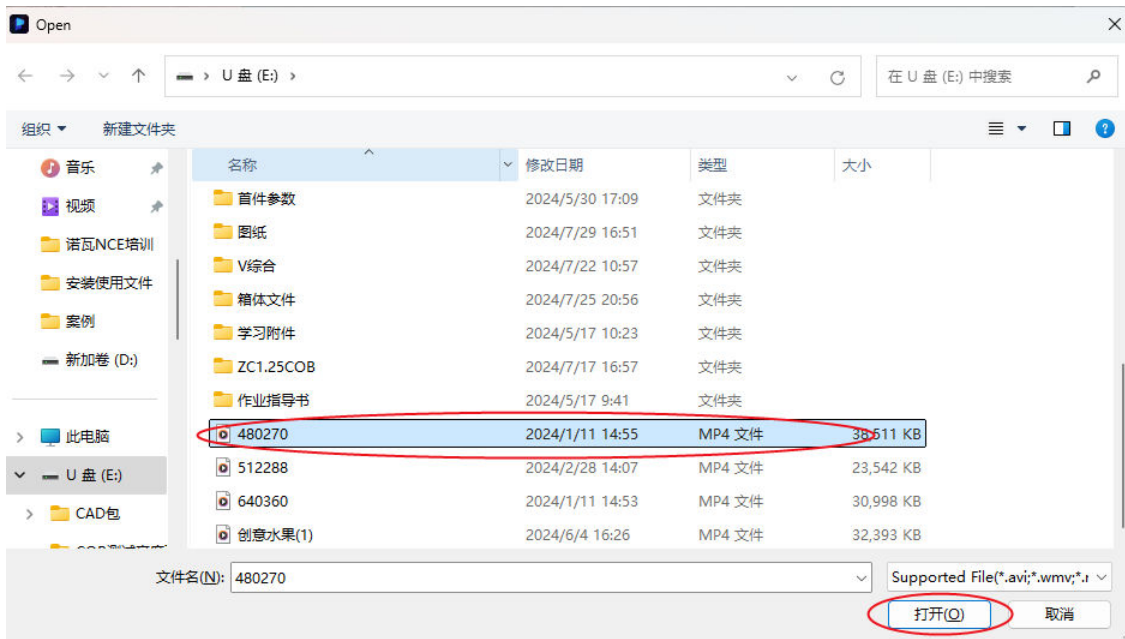

Fig 4-25 Video/Image Settings W/H Add

## Step 3: Add video source



## Step 4: as shown

Fig 4-26

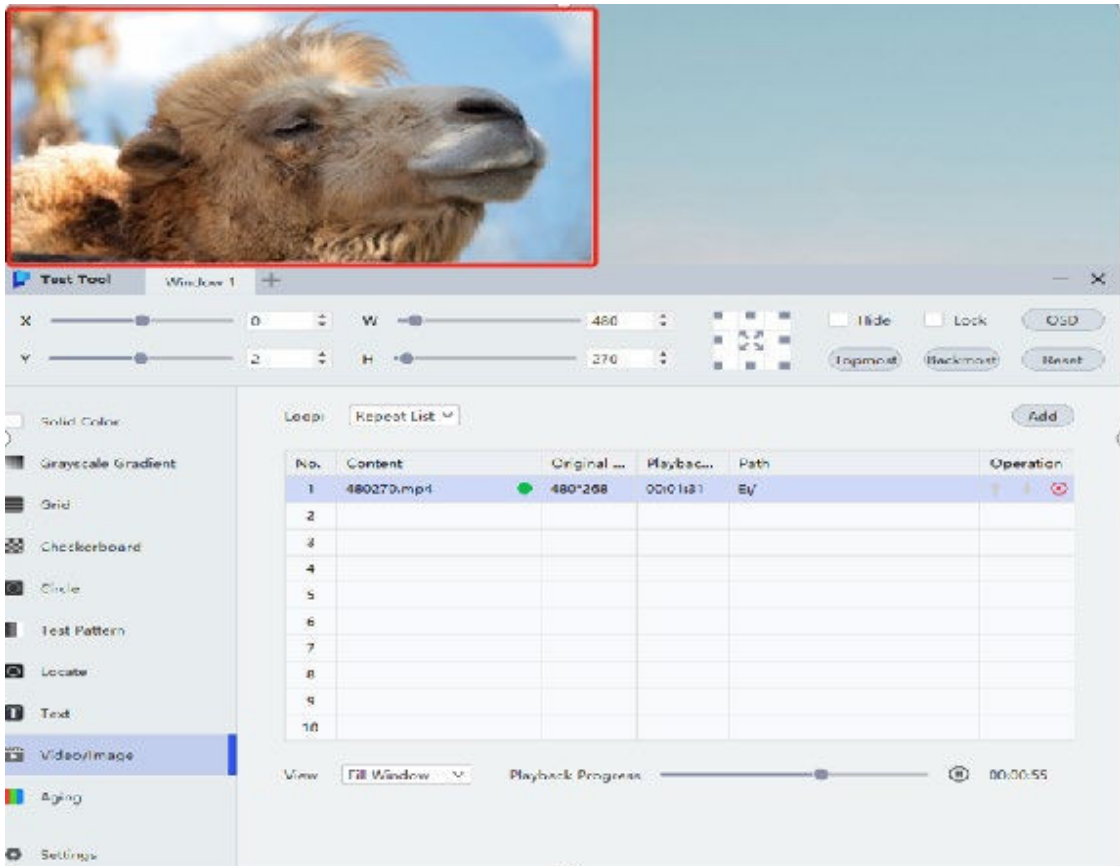

Fig 4-27

## Chapter 5: Hardware Troubleshooting Analysis

### 5.1 Module Failure:

Fault type	fault description	Symptoms and Solutions	Cause
LED light	Dead Lamp	Replacement of Modules	Dead or Bad Soldering
LED Pixel Block	Pixel Block Black or Missing Color	Replacing an IC or Module	Driver IC/Resistor Poorly Soldered or Not Working
LED Modules	One or More LED Modules in a Row are Black or Faulty	Check the Connection of the Module to the Adapter Board	Not Connected or Poorly Connected



Fig 5-1

If the above defects occur, prioritize replacing the spare module. If the module still fails after replacement, check and replace the connecting board and the firmware of the receiver card.

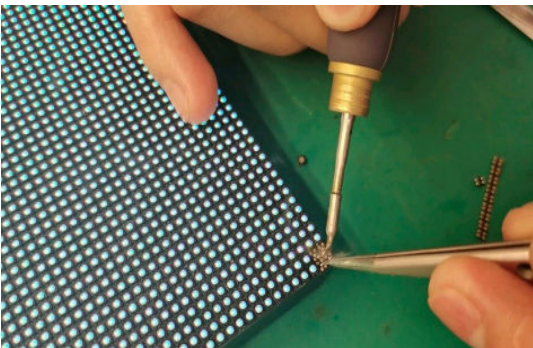

Fig 5-2

Replace the problematic module and check for poor contact, dead lights, black or color blocks. If the driver IC is not functioning due to false welding, welding, or replacement issues, contact our technicians for further assistance.

## 5.2 Power Failure:

Fault Type	Fault Description	Symptoms and Solutions	Cause
Power Supply Module	The entire module is black	Check the power connection of the module	Poor power-to-module connection
Power Supply	The entire module is black	Replacing a faulty power supply	There's a problem with the power supply that powers the receiver card.
Power Supply	Several neighboring module areas are black	Replacing a faulty power supply	There's a problem with the power supply that powers the receiver card.

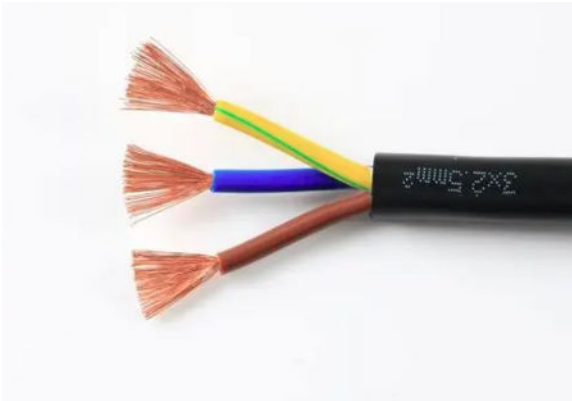

Fig 5-3

Prioritise checking the power cord for poor contact



Fig 5-4

If multiple adjacent module areas are black:

1. Check if the receiver card signal light is functioning.
2. Use a test pen to verify power supply output.
3. Replace the power supply if no voltage is detected.

## 5.3 Data Transmission Faults:

Fault Type	Fault Description	Symptoms and Solutions	Cause
Fiber Optics	Black screen	Check fiber optic connections and data I/O sequence	Fiber optic cable damage or data I/O errors
CAT5e	Black screen of the whole column of the display	Check the network cable between the sending cabinet and the first scan card	Bad connection or faulty RJ45
CAT5e	Black screen of one of the modules in a column	Check RJ45 cables between modules	Bad connection or faulty RJ45
CAT5e	All modules are lit, but the order of each column is not correct	Check and correct the RJ45 cable connection order	Incorrect connection sequence



Fig 5-5

Check the signal lamp to determine if it is functioning. If the display is abnormal, investigate the faults described above one by one.



Fig 5-5

## 5.4 Regular Maintenance and Precautions

- Ensure that the LED display is well ventilated, dry and operating at the right temperature.
- Regularly check the internal components of the LED display to ensure that the cables are connected correctly, the power supply is working properly, the ground wire connection is not damaged, and the lightning arrester is operating properly.
- Regularly clean the LED module surface with an anti-static soft brush to maintain display cleanliness and prevent brightness inconsistencies.
- Precautions for use.
- Power on the LED display first, followed by the remote display.
- Before shutting down the display system, turn off the power of the LED display first, then turn off the computer.
- It is best to turn off the LED display when editing a video playlist.
- In case of a fault, turn off the power of the LED display first, and then contact our technical service department for technical support.

### ■ EASY FRONT SERVICE DESIGN

The cabinet and the module are packed separately, the cabinet is installed first and then the module, and the cabinet and the module are connected through pin headers. Intelligent adjustment: The unique 6-axis alignment function ensures that the video wall is perfectly aligned and seamless, and the screen flatness tolerance is less than 0.1mm

The final installation of the product requires steel structure bracket fixation, and professional front maintenance tools are used to disassemble the LED module.



①



②



③



④